



D7.6 Report on conservation compatibility of the developed solutions and methods

**EUROPEAN COMMISSION
DG Research and Innovation**

Seventh Framework Programme

Theme [EeB.ENV.2010.3.2.4-1]

**[Compatible solutions for improving the energy efficiency
of historic buildings in urban areas]**

Collaborative Project – GRANT AGREEMENT No. 260162



The European Union is not liable for any use that may be made of the
Information contained in this document which is merely representing
the authors view



Technical References

Project Acronym	3ENCULT
Project Title	Efficient ENergy for EU Cultural Heritage
Project Coordinator	Alexandra Troi EURAC research, Viale Druso 1, 39100 Bolzano/Italy Alexandra.troi@eurac.edu
Project Duration	1 October 2010 – 31. March 2014 (42 Months)

Deliverable No.	D7.6
Dissemination Level	PU
Work Package	WP 7 Design tool and quality assurance
Lead beneficiary	No 3 IDK
Contributing beneficiary(ies)	Partners in LCS-Teams
Author(s)	Christoph Franzen (IDK)
Co-author(s)	Members of the LCS-Teams
Date	Feb. 25 th , 2014
File Name	WP7_D7.6_20140225_P03_ConservationCompatibilityReport.doc

Table of Content

1	Introduction.....	4
2	Evaluation per case study.....	5
2.1	CS1 Public Weigh House, Bozen/Bolzano (Italy).....	5
2.1.1	LCS-Team	5
2.1.2	Heritage value of single building elements from conservation point of view.....	5
2.1.3	Internal surfaces (walls and ceilings).....	5
2.1.4	External surfaces/facades	7
2.1.5	Roof	8
2.1.6	Installation work (holes, chimney)	9
2.1.7	Windows	10
2.1.8	References	24
2.2	CS2 Palazzo d'Accursio, Bologna (Italy).....	25
2.2.1	LCS-Team	25
2.2.2	Conservation issues integration	25
2.3	CS3 Palazzina della Viola Bologna (Italy).....	66
2.3.1	LCS-Team	66
2.3.2	Building measures and conservation compatible efficiency solutions.....	66
2.4	CS4 The Material Court of the Fortress, Copenhagen (Denmark).....	67
2.4.1	LCS-Team	67
2.4.2	Efficiency solutions and Heritage Authority comments	67
2.5	CS5 Secondary School NMS Hötting – Innsbruck (Austria).....	73
2.5.1	LCS-Team	73
2.5.2	Denkmalbegründung	74
2.5.3	Efficiency solutions and Heritage Authority comments	76
2.6	CS6 Warehouse Potsdam, House Dresden, House Freiberg, House Görlitz (Germany).....	80
2.6.1	LCS-Team/s.....	80
2.6.2	Round table, additional information	81
2.7	CS7 Industrial Engineering School-Béjar/Salamanca (Spain).....	100
2.7.1	LCS-Team	100
2.7.2	Integration of heritage office in CS7	100
2.8	CS8 Strickbau Appenzell (Switzerland).....	101
2.8.1	LCS-Team	101
2.8.2	Integration of heritage office in CS8	102
3	Remarks	104

1 Introduction

The deliverable D7.6 Report on conservation compatibility of the developed solutions and method based on the task 7.6 Preservation issue surveillance should reinsure the conservation compatibility of the developed products and methods within 3ENCULT. Conservation experts provide a final analysis and comments on the selected deliverables from the conservation point of view. As within the 3ENCULT project some conservation experts were involved and influenced the project actions as far as their recommendations were accepted, the conservation compatibility of the results has to be evaluated from external conservation experts and from the persons in charge of the monument conservation of the case studies. The close integration of the heritage offices was one main steps in the continuous dialog between the different stakeholders within 3ENCULT project leading to optimised solutions and a common language and a better overall understanding of the complex issue of energy efficiency applications in cultural heritage. Within the LCS-teams the dialog achieved different intensity. Moreover, written documents from the legally responsible conservation offices in charge of the case studies were difficult to gain. Thus documentation of the intense dialog between the energy efficiency experts and the conservation experts, which accompanied the project in all phases is small in some cases. The successful dialogue for sustainable energy intervention actions is based on teams where stakeholder, user, planner and the conservation and energy experts are involved.

The deliverable D7.6 does present the conservatory view point for each single case study of the 3ENCULT project. Naturally the state and form of information for all the study cases is diverse.

2 Evaluation per case study

2.1 CS1 Public Weigh House, Bozen/Bolzano (Italy)

2.1.1 LCS-Team

Case study leader/ 3ENCULT responsible partner:

Dagmar Exner, Alexandra Troi (P01)

EURAC research, Drususallee 1, I-39100 Bozen

Building owner:

Stiftung Südtiroler Sparkasse, Talfergasse 18, I-39100 Bozen

Silvia Amonn (contact person for LCS-Team)

Conservator: director of the local state office for historical monuments

Dr. Waltraud Kofler Engl (director)

Landesdenkmalamt Südtirol, Amt für Bau- und Kunstdenkmäler, Armando-Diaz-Straße 8, I-39100 Bozen

Architect/Project planner: to be involved after the selection through competition

2.1.2 Heritage value of single building elements from conservation point of view

The following text describes the heritage value of single building elements of the Public Weigh House, case study within the project 3ENCULT. The evaluation of the components has been developed in a conversation between the case study responsible and the conservator (director of conservation office of South Tyrol). Thereby the case study responsible asked practical questions regarding the historic, technical and artistic value of the single component as well as to what extent it could be changed or covered. The assessment reported here is therefore a summary of these interviews.

We discussed and studied one component of the building more in detail: the window. As in this specific case the major part of the existing windows are not of historic value, as they have been exchanged during the 50th/60th of the last century, it was the aim within the project 3encult to develop a high energy efficient window, that substitutes the existing window and answers to the heritage demands of the building. During the development process, we aspired a strong collaboration with the conservation office. The conservator accompanied and evaluated every design step/interim solution.

2.1.3 Internal surfaces (walls and ceilings)

Actual state of the building concerning inner surfaces:

Construction: Most internal partitions are of natural stones with lime mortar joints. The stonework is covered in most parts on both sides with lime plaster. In some cases the stonework is supported by a wooden framework. Some inside partition walls are only from the last century and therefore constructed in brick masonry or in dry construction.

- Inner surfaces: in some parts: wall painting/fresco
- In general: historic wall surface layers (painting and lime plaster)
- In parts of the building: stuccoed ceilings, vaulted ceilings

Assessment of the conservator:

The building has evolved over the ages to what it is now. The layers of paint, the appearance of the historic plaster, the uneven surfaces and edges allows us to perceive the history of the building, they make the biography of the house readable. From conservators point of view the inner surfaces of a building are like the skin of a human being. They have to be preserved for historic and handcraft reasons.

Wall paintings in connection with historic plaster are the most valuable surfaces. In case of the Public Weigh House, we have traces of wall paintings from baroque era and from the early modern times and frescos in the bay room. The majority of the mural paintings is covered by paint layers and only partially visible. In these cases, the conservator would have to decide and analyse room by room, fresco by fresco whether an exposure is feasible and useful from preservation point of view. The vaulted ceilings, as well as the historic inner plasters are of historic value and therefore worth for preservation.

Possible interventions:

- (Temporary) installation of internal insulation in carefully selected parts of the building possible

For the installation of the window prototype and for the within the project developed internal insulation a “test room” on north east side of the first floor of the building has been selected together with the conservator.

Recommendations by the conservator regarding internal insulation in general and in the test room:

- Internal insulation should be in any case removable and should not leave any trace on the existing walls.
- Existing wooden pavement (in chosen test room) should be conserved.
- Usual approach of renovation of inner side of the wall in similar cases: Uncover the last useful layer (that still has to be determined) and paint this layer with limewash.
- In general: the covering of surfaces has to be decided individually room by room from the conservation point of view. Also in case of ancillary rooms, it has to be decided individually about the technical and aesthetical value of the surfaces.
- Problems of internal insulation from conservation point of view: covering of historic surfaces in a way that they are no more visible and “perceivable”, changing symmetry of stuccoed ceiling, changing the delicate original proportions of the rooms

2.1.4 External surfaces/facades



Figure 2.1: East and south façade of the building

Actual state of the building concerning outer surfaces:

Construction: Besides some little exceptions over the whole facades: “Schichtmauerwerk” horizontal layer with continuous horizontal joints out of “Bachsteine” (Stones from a stream) in granite not worked. In between lime mortar joints. The stonework is covered from inside and outside with lime plaster, substituted partially with a cement plaster (outside).

- Outer surfaces: in some parts: wall painting/fresco
- In general: historic wall surface layers (painting and lime plaster):
- Window frame in profiled sandstone from baroque era

Assessment of the conservator:

The façade shows us the construction history of the building: on the south side, the façade has a baroque appearance. We have the frescos, which represent the armorial bearings of Austria, South Tyrol and the city of Bolzano. On the east side, we see the Romanesque masonry with the typical execution of the mortar joints for that time. All over the whole building, we have historic plaster, which are of historic value and therefore worth for preservation. The historic plaster, the frescos, the sandstone frames around the windows, the original proportions of the façade should remain perceivable and therefore not be covered.

Possible interventions:

- No interventions possible from conservators point of view

2.1.5 Roof



Figure 2.2: Roof of the building from outside and inside, isolated and non-isolated part

Actual state of the building concerning outer surfaces:

Construction: Purlin roof with wooden rafters and wooden casing. Roofing cardboard (bitumen) on the wooden casing, above it roof cladding with tiles (Spanish tile roof). In the current state, the roof construction is partially insulated with a layer of mineral wool of 8 cm to the inside, in between the wooden rafters. The insulation is covered on the below side by a gypsum plasterboard.

Assessment of the conservator:

From conservator's point of view, the roof has to be preserved in his actual form for two main reasons:

- The Spanish tiles ("Mönch und Nonne") of the saddle roof are historic tiles. They have a value from conservators point of view because they're handcraft manufactured in a unique way
- The homogeneous appearance of the roof scape of the whole historic city centre has to be kept. To assess the roofs not only the visibility is crucial but also the uniformity. Apart from that, the visibility of the roof areas can't be evaluated standing besides the building and looking to the roof; it must be considered that the whole roof scape of the historic city centre of Bolzano is ascertainable, looking from the surrounding mountains.
- Not only the appearance of the roofage has to be kept, also the lower side of the roof (down spout) can't be changed by f. e. rising the roof covering, in case of putting insulation of the roof above the rafters. The profile and the proportions of the roof-edge should be preserved.
- Insulation of the roof: an insulation from inside is thinkable (insulation in between and below the rafters).

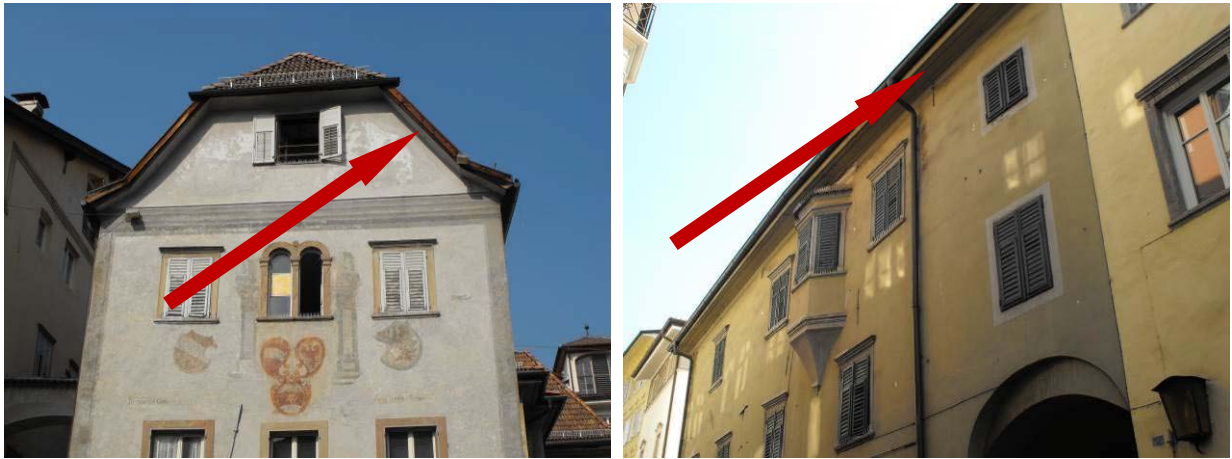

Figure 2.3: Down spout of the roof

Dormer windows:



Figure 2.4: Roof dormers of the Weigh House

In case of dormers of a roof, the heritage office usually recommends two type of shapes for the historic city centre: either single dormers with external dimensions of 1,2 x 1,2 m or a long row of windows parallel and near to the roof ridge with a width of 0,7 m.

2.1.6 Installation work (holes, chimney)

Recommendations of the conservator:

- For installation work use as much as possible existing wholes, inspection chambers and chimneys
- For the installation of ventilation channels the existing chimneys can be used
- For horizontal distribution of installation cables and tubes existing space in the floors and ceilings should be used
- In case if there have to be stemmed slots and apertures for vertical distribution of cables and tubes, it has to be analysed and decided individually if it is possible because of mural paintings
- If possible, the vertical distribution of cables and tubes should be avoided: floor sockets should be inserted or cables should be laid on-wall.

- In case of existing holes or apertures in the exterior wall, it has to be decided individually if they can be closed according to their position and original function.
- If there is no need to use existing holes in the building structure or if they don't have a relevant function, they can be closed. The closure of holes has to be documented during the process of construction.

2.1.7 Windows

2.2.7.1 Situation before development of first window prototype

Elaborated within the "Workshop on windows", 26th August 2011. See also: WP6_20110830_P01_Workshop windows meeting minutes

Actual state of the building concerning windows, before developing the first window prototype:

The main part of the existing structure is from the early middle age, extensions were made during the gothic period. In the end of the 16th century, there was a large reconstruction of the building, unifying e.g. the dimensions of window apertures and extending the building on the east side. The window size is therefore typical for baroque era. The major part of the original windows, above all on first and second floor, were replaced by box-type windows from the 50th/60th of the last century. All of these windows are not of historic value from conservator's point of view. This means that all of these windows should be replaced by a reproduction of a historic window. As there are no documents or information available on the type of the original historic window, the conservator proposes to base the new window on a "classic" window in terms of function, division and proportion.

Possible interventions from conservators point of view:

- Installation of a prototype
- Replacement of windows during planned refurbishment

Recommendations by the conservator regarding the first window prototype:

Mrs. Kofler-Engl, director of conservation office of South Tyrol and member of the Local Case Study Team, recommends a window with two sashes with two sash bars each sash. It could be a box-type window, a coupled window or an insulating glass window. In every case, the layer of the outer window should be placed behind the existing stone frame. In case of a box-type window the deepness of the box should be similar to the actual windows from the 50th/60th. It should be positioned and installed in the reveal in a similar way.



Figure 2.5: Existing window from the 50th/60th of the last century from inside and outside

2.2.7.2 Feedback after development of first window prototype



Figure 2.6: First high energy efficient window prototype installed in the Weigh House
Comment by Dr. Kofler Engl (Director of the Heritage Office of South Tyrol) regarding the first window prototype, developed in the framework of the research project 3Encult:

28.02.2012

Single glazing outer window sash:

- The optic of the single glazing seems to be "over the top". It does not correspond to the appearance of a historic glass. From the outside, to highly irregular reflection, from the inside to strong irregularities.
- The Heritage Office has not yet found a satisfactory type of glazing that would come closest to the historic glass. It can therefore not make any recommendation for the outer glazing.
- A single glazing in conventional float glass is preferable to the glass used now.

Proportions / Subdivision / Frame thickness:

- Overall positive impression of frame and sash bar thickness
- Also the subdivision and the proportions are suitable

Evaluation of the concept of "division of functions":

- The division of functions in **historic window sash** (outer sash) and **energy efficient sash** (inner sash) does not correspond to the function and execution of a coupled window. A classic coupled window at first would be closed all around the joint of the two superposed sashes - both sashes plus the composite structure would have an energy function - and would secondly be openable and therefore easier to clean. It is not clear why the outer layer has no energetic function, but only an optical function - this appears "dishonest".
- Triple glazing is highly questionable for Bolzano/South Tyrol climate. The conservation office does usually not approve triple glazing in a listed building. The black spacer attracts attention negatively, particularly because it is at the same level with the surrounding edge of the wooden frame.
- Maybe you could make a double glazing in the inner sashes and in the outer sashes remains the single glazing, but by closing the joint around the two window sashes and creating a composite, the whole "package " would have an energetic function or at least the energy efficiency of the inner double glazing would be improved through the outer sash.
- Overall, a double glazing with interior and exterior glued on sash bars would still be preferable in comparison to this actual solution.

Colour / Profiling:

- Colour inside is suitable
- Probably the outside colour will have to be adapted (after refurbishment) after the determination of the façade paint. Now it is too bright or the contrast a bit too strong compared with the paint of the exterior façade.
- The profile on the inside of the inner sash ("Glass Bar") should not be rounded off in the corners, but it should be made angular.

Overall summary:

The prototype as it is installed now in the Weigh House would not be taken as a substitute for the existing windows.

2.2.7.3 Input for the development of a second window prototype

Elaborated within the "Workshop on windows", 09th April 2013

1. Window/Façade concept for the Public Weigh House:

Except some few original windows from the late baroque era, the existing box-type window of the Public Weigh House (which are mostly from the 1950th/60th) should be replaced through by a new

coupled window. Franz Freundorfer, the window developer, therefore develops further the already existing coupled window prototype. The dimensions and proportions of the new composite window should refer to the original baroque window, from which in some rare cases there is still an outer window frame with a horizontal impost, which was cut out.

In that cases, where it is a late baroque original window, it should be preserved and repaired and possibly be enhanced from energetic point of view by an additional second window layer.

Worth preserving original windows from the late baroque era:

- The three window in the bay on 2nd floor on the north side
- Possibly the one sash window on 2nd floor on the west side
- Possibly the window in the staircase on 2nd floor on the west side
- Possibly the two sash window in the toilet on 1st floor on the east side (where the window sash and frame are baroque, but the fitting from the early 20th century)



Figure 2.7: Photo from the Weigh House from 1958: On first floor, you can see the original baroque window with the horizontal impost

2. Recommendations for the further development of the composite window prototype for the Public Weigh House:

- The proportions and dimensions of the new composite window should correspond to those of the baroque window. Like the original baroque window, it should have a horizontal impost and four window sashes (2 above, 2 below). As a template for that, and for the position of the impost, the existing baroque window in the Weigh House is used (see measures in the sketch). The two lower sashes should have each a sash bar. The window sashes on the inner side should not flush with the window frame.
- Based on these windows' dimensions, Franz Freundorfer develops a drawing, which is then discussed with the conservator. Based on his drawing and suggestions, questions regarding the shape and appearance of the weatherboard, type of sash bars, selection of fittings etc. are clarified. The colour of the window must be determined before the production (possibly based on colour samples taken from the original window by the historian Mr Mittermair).
- From energetic and conservation point of view it is still to clarify the definitive version of the glazing (evaluation double and triple glazing).

- When replacing the windows it must be assumed that the window reveal and inner (and outer) surface of the exterior wall for conservation reason cannot be insulated. Therefore, it must be guaranteed an adequate room ventilation (removal of moisture) in order that through the increased air tightness of the windows no condensation problems arise at the cold surface of the exterior wall. The chosen building physics concept should not only work for a “museum of photography” (planned use of the Weigh House in the future), but also in case of a change of the use of the building.
- The new prototype should be installed in the Weigh House until the EWCHP in September 2013.

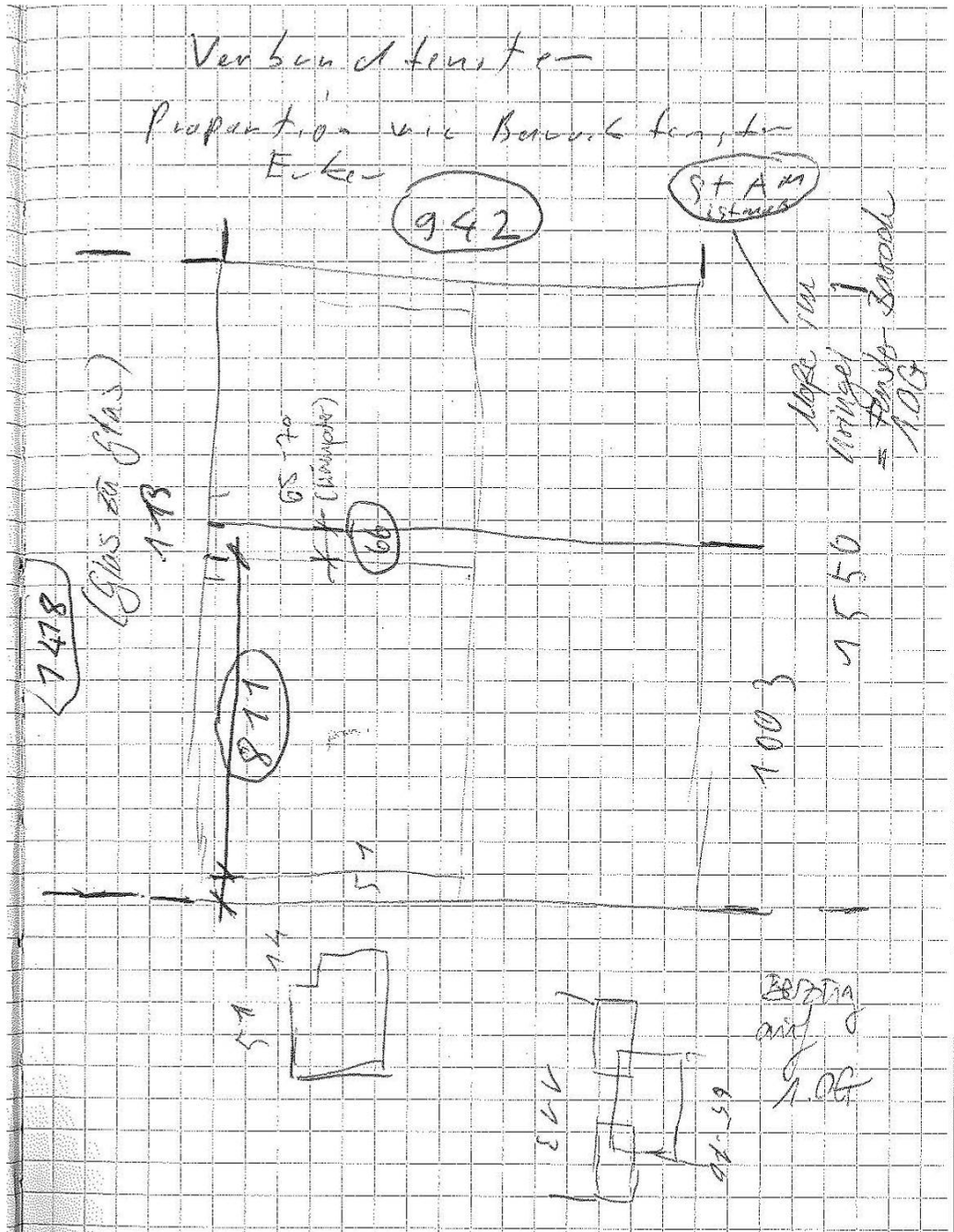

Figure 2.8: External dimensions of the window and position and dimensions of the horizontal impost at the bay window and at the baroque window frame on the first floor (in the loops).



Figure 2.9: Shape of the impost at the bay window on second floor

3. Development of an energy-efficient solution for the original baroque windows

- The three windows of the bay should be preserved, they should be restored and repaired and improved from energetic point of view by an additional window layer.
- Solution: removing the existing wooden frame outside, which serves for the fixing of the window shutters. Instead of the wooden frame outside provide a second window layer, which takes over the energy efficient function (concept of the composite window prototype “upside down”). The outer wing can be opened to the outside; it can be executed without the horizontal impost (only one sash).
- The refurbishment solution for the bay windows should serve as an example for an individual case, which means a case where the original window should be preserved and where a solution for energetic improvement must be found individually. The solution should be developed in terms of drawings and heat-transfer calculations (in THERM) to the extent that they are executable. There will be no prototype built for this case.



Figure 2.10: Bay window on second floor (from outside and from inside)

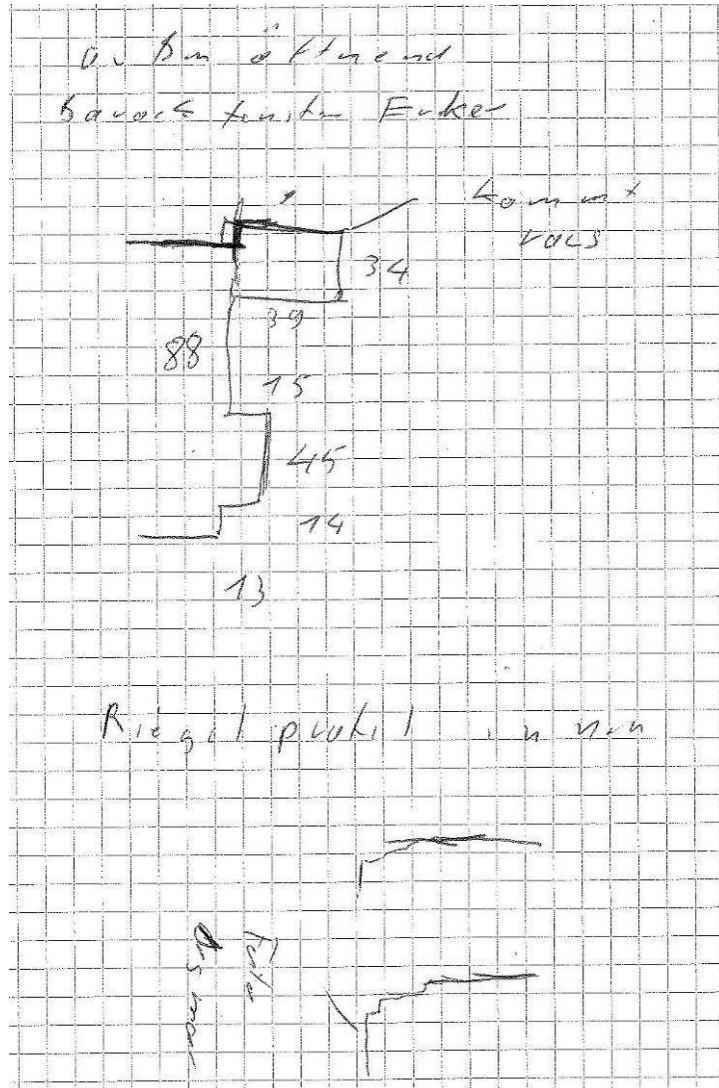

Figure 2.11: Dimensions of the bay window: window frame, exterior reveals and wooden frame on the outer side for fixing the window shutters

4. Development of an high energy efficient prototype for a box-type window typical for Bolzano from the turn of the last century (1900)

- For the development of an energy-efficient box-type window a box-type window from the turn of the century typical for Bolzano is used as a model
- Appearance, proportions, dimensions and division of the prototype should correspond to those of the model. As template window, the windows from the “Aufschnaiter Middle School” (Leonardo da Vinci Road 13) are selected. The window sashes be able to open inwards.
- The external dimensions (length * width) and the position of the horizontal impost are measured on-site by the case study responsible, the remaining dimensions/proportions assumes the window developer from the photo.
- The prototype is expected to be produced (in coordination with the company Andre) by the company Kranz. It will not be installed, but can be presented “free-standing” at seminars and fairs.





Figure 2.12: Box-type window of the “Aufschnaiter Middle School” in Bolzano

2.2.7.4 Feedback before production of the second window prototype

Summary of the comment by Dr. Kofler Engl (Director of the Heritage Office of South Tyrol) regarding the drawings (see below) of the second window prototype, developed in the framework of the research project 3Encult, plus decisions between the case study responsible and the window developer:

13.06.2013

General decisions between the case study responsible and the window developer:

- Comparison of the energetic parameters of the window with two glazing solutions: once with double glazing and once with triple glazing: comparison of the U_w -value, the g -value (total) and the Ψ values (installation and glass edge) and the light transmittance (τ value).
- Comparison of energy savings (taking into account the transmission heat losses, solar gains and daylight potential) when using double and triple glazing at the example Public Weigh House (and possibly at the example "Aufschnaiter School"). Comparison of the costs.
- For the single glazing outside ("Restauro leicht") there is no g -value and τ -value available by the manufacturer. For the measurement of these parameters, the expert for daylighting and artificial lighting will be contacted and involved.
- The case study responsible will do the comparison of the energy balance implementing the two glass types.
- For determination of the Ψ -value the case study responsible will elaborate different detail sketches of the window connection (with the outer wall): one with internal insulation (iQTherm) and one without internal insulation. Franz Freundorfer will then determine the Ψ -values with THERM.
- Based on several rooms the case study responsible will simulate and compare the use of daylight for both glass type applications.
- The prototype will be realized with the two glazing solutions inside: use of a double glazing (22 mm) in two window sashes (below and above) and use of the triple glazing (2/8/2/8/2) in the other two window sashes. The aim is to be able to compare the two solutions on-site from optic point of view.
- Selection of one window in the building that will be replaced by the window prototype and control of the dimensions (clear dimension window opening outside + depth "Mauerfalz") -> Case study responsible
- In the new drawing, all dimensions that have to be controlled on-site by the case study responsible are marked in colour.

Comment of the conservator with regard the coupled window for the Public Weigh House:

- Colour of frame and sashes (outside): specification of the conservator is a "light grey". Frame and sashes (inside): in an "off-white". The specification of the colour of the glass edge seal is that its colour must correspond to the colour of the frame. Since there is only a limited selection of colours for the glass edge seal, the colour of the frame and sashes will be adapted to that of the glass edge seal. Normally for the definition of the window colour, a study

of the façade colour is carried out (exposing the original paint layers and determining which layer is taken), in which the façade and window colour is specified.

- Colour of the silicone joints: should also correspond to colour of the respective frame
- Type of window handle: same as on the drawing. The size of the handle is suitable, the “Schild” should be smaller. As material brass shouldn’t be used.
- Single glazing outside: “Restauro leicht”
- Triple glazing inside: still questionable from aesthetical and functional point of view
- Type of wood: local timber: pine or larch. Since the wood is varnished spruce is more recommendable.
- Profiling inside and outside: like in the drawing
- Weatherboard: Production of the weather board on the above and below window sashes in timber (“overlap” at the joint of the two window sashes in metal) -> see drawing
- Horizontal impost: the design of the impost has to be revised. The impost should be a “T-piece” with a profile on the outer side -> see drawing
- Sash bars: the width of the sash bars seems a bit narrow. Please compare the design of the sash bars with that of the first window prototype – the width of the sash bars was suitable in that case. -> The window expert will study a solution where the sash bars are “interrupted” by the glazing.

Box-type window Aufschnaiter Middle School:

- Control of the dimensions/position of the impost corresponds to the original historic window. It is accepted.
- Colour of frame and sashes (inside and outside): specification of the conservator is a “light grey”. The specification of the colour of the glass edge seal is that its colour correspond to the colour of the frame. Since there is only a limited selection of colours for the glass edge seal, the colour of the frame and sashes will be adapted to that of the glass edge seal
- Colour of the silicone joints: should also correspond to colour of the respective frame
- Type of window handle: same as on the drawing. The size of the handle and of the “Schild” is suitable. As material brass shouldn’t be used.
- Single glazing outside: “Restauro leicht”
- Triple glazing inside: still questionable from aesthetical and functional point of view
- Type of wood: local timber: pine or larch. Since the wood is varnished spruce is more recommendable.
- Profiling inside and outside: like in the drawing
- Design of the upper window: rebating inside and on the above side tiling to inside

WP7_D7.6_20130930_P03_ConservationCompatibility

- Weatherboard: Production of the weatherboard on the upper and below window sashes in timber (“overlap” at the joint of the two window sashes in metal) -> see drawing
 - Horizontal impost: the design of the impost has to be revised. The impost corresponds to that of the original window (see photo) -> see drawing
 - Sash bars: provide sash bars also on the inner window sashes, as in the original window (see photo). Glue sash bars on the inner and outer side of the inner window sash.
-
- Also this prototype will be realized with the two glazing solutions inside: use of a double glazing (22 mm) in two window sashes (below and above) and use of the triple glazing (2/8/2/8/2) in the other two window sashes. The aim is to be able to compare the two solutions on-site from optic point of view.
 - In the new drawing, all dimensions that have to be controlled on-site by the case study responsible are marked in colour.

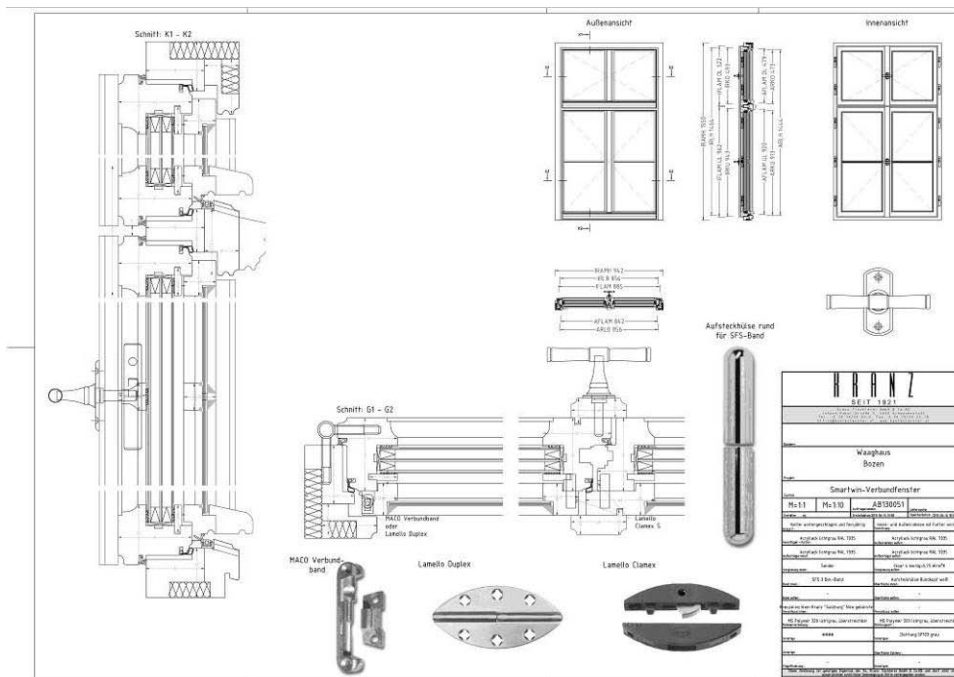

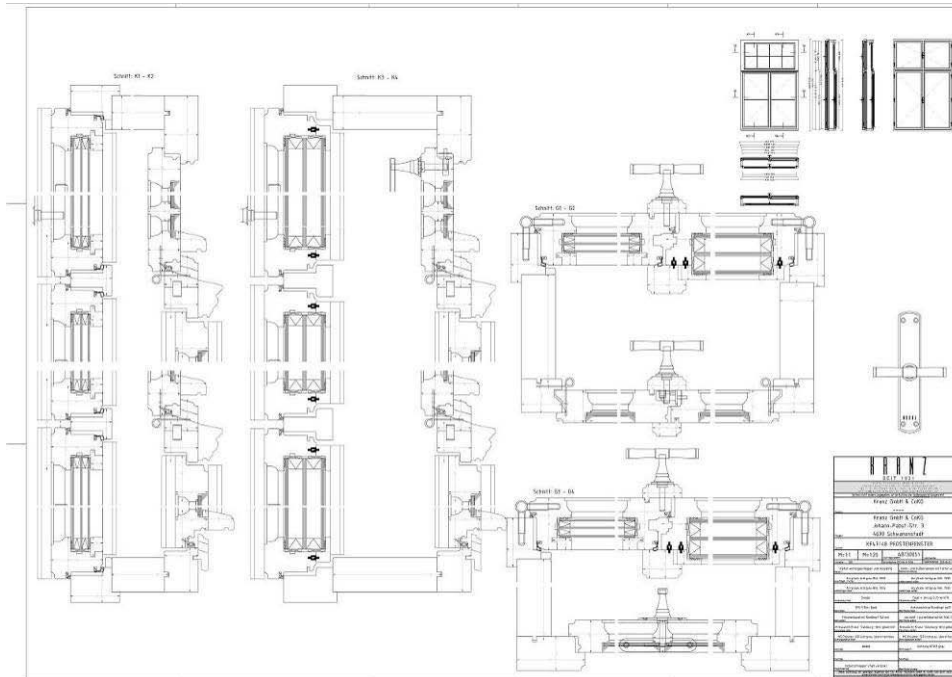

Figure 2.13: Drawings of the second window prototype for the Public Weigh House (above) and the prototype for a typical box-type window of Bolzano (below)

2.1.8 References

Project internal references

- **Minutes of “Workshop on windows”, 26th August 2011:**
WP6_20110830_P01_Workshop windows meeting minutes
- **Feedback of the conservator regarding the first window prototype 28th February 2012 (in German):**
WP6_20120228_P01_Feedback conservator first window prototype
- **Minutes of “Workshop on windows”, 09th April 2013 (in German):**
WP6_20130412_P01_Workshop windows meeting minutes
- **Feedback of the conservator regarding the drawings of the second window prototype 13th June 2013 (in German):**
WP6_20130613_P01_Feedback conservator drawings second window prototype

2.2 CS2 Palazzo d'Accursio, Bologna (Italy)

2.2.1 LCS-Team

The exact constitution of LCS-Team is based on 3encult partner and Stakeholders listed below:

1. Municipality of Bologna COBO (P10) composed by:

- process responsible: ing. Fabio Andreon (executive Public Works Dept.);
- scientific responsible: arch. Manuela Faustini Fustini (Cultural Heritage, Public Works Dept.);
- arch. Arturo Todaro (Designer for extraordinary maintenance, Public Works Dept.);
- p.i. Capuzzi Davide (Plant engineer expert, Public Works Dept.);
- dott.ssa Pamela Lama (International relations and projects Office);
- dott. Francesco Tutino (Environment and energy Dept.);
- dott. Daniele Zappi (Environment and energy Dept);
- arch. Federica Legnani (Old town planning).

2. University of Bologna composed by:

- arch. Camilla Colla (non-destructive analysis and tests);
- ing. Elena Gabrielli (non-destructive analysis and tests);
- ing. Marco Giuliani (energy analysis and simulations);
- ing. Francesco Ubertini (DICAM department responsible);
- ing. Giacomo Paci (Wireless sensor networks).

3. Artemis srl composed by:

- ing. Enrico Esposito (IR thermography tests and indoor monitoring);

4. Icie – Larcolcos Laboratory (supplying specialist guidance in the environmental energy improvement) composed by:

- Arch. Valerio Nannini;
- Ing. Sandra Dei Svaldi;
- Arch. Mena Viscardi.

5. IBC- Regional Institute of Cultural Heritage (architectural and environmental heritage field that carries out support to local authorities for the understanding, conservation and enhancement of the architectural and natural heritage) composed by:

- arch. Piero Orlandi
- arch. Andrea Zanelli

6. Heritage Preservation Authority office for the provinces of Bologna, Modena and Reggio Emilia (Department for architectural treasures and landscape for the provinces of Bologna, Modena and Reggio Emilia. Organisation approving the interventions to be implemented in the project) composed by:

- arch. Franca Iole Pietrafitta (project officer)
- arch. Paola Griffoni (Heritage Preservation Authority Director)

Meetings of the total LCS-Team as listed above were hard to organise. Moreover the planning and execution of energy efficient measures was integrated in other complex building works leading to additional challenges for integrating 3ENCULT LCS-team proposals.

2.2.2 Conservation issues integration

Additional information was contributed by COBO and is given in the following pages.



D 2.2 Contribution from Case Study2 Palazzo d'Accursio /Municipal Palace Bologna (Italy)

**EUROPEAN COMMISSION DG
Research and Innovation**

Seventh Framework Programme

Theme [EeB.ENV.2010.3.2.4-1]

**[Compatible solutions for improving the energy efficiency
of historic buildings in urban areas]**

Collaborative Project – GRANT AGREEMENT No. 260162



Table of Content

1	Formal commitments between the Owner, the local Authority, the Preservation Authority ..	3
1.1	The Italian legislations for the preservations on cultural heritage.....	3
1.2	The case study of Palazzo d’Accursio and its specific issues	3
1.3	The Local case Study Teams.....	4
2	The conservation aspects and energy saving actions for the “Sala Urbana” in Palazzo d’Accursio	5
2.1	The “Palazzo d’Accursio”	5
2.1.1	Local climate data	5
2.1.2	Report on history of the building	5
2.2	Constraint and protection conditions.....	16
2.2.1	Principles of protection given by the Authority for Cultural Heritage.....	16
2.2.2	Limits and prescriptions determined by the Owner.....	18
2.2.3	Limits and prescriptions arising from Area Regulations.....	18
2.3	Selected area of intervention	18
2.3.1	Functional Area 1 - Municipal Collections (2nd floor)	18
2.3.2	Analysis and monitoring results (status pre-intervenction)	19
2.3.3	Design Builder applications results (current status of the building)	20
2.3.4	Energetic retrofit proposal for Sala Urbana	27
2.3.5	Project energy simulations for achieving the most efficient solution for conservation.....	30
3	Project of the interventions and formal approval by the Heritage Preservation Authority ..	33
3.1	Guidelines for interventions (Municipal collections)	33
3.1.1	Roof refurbishment	33
3.1.2	Windows substitution	35
3.1.3	Domotics equipment installation	38
3.1.4	New led-lighting devices	38
3.1.5	Authorization to proceed with the realization of works.....	39

1 Formal commitments between the Owner, the local Authority, the Preservation Authority

The case studies in Bologna, Palazzo d'Accursio, is considered Monuments of **high historical architectural value**. He is located within an historically and totally urbanised urban context. In particular, Palazzo d'Accursio is located in the oldest city nucleus on the foundations of the ancient Roman city. The case studies can be considered as relevant examples of monuments placed in the city centre, whose projects aimed at the improvement of environmental comfort and energy efficiency can become a guide to improve and implement current municipal regulations.

Project proposals, derived from the historic and architectural-structural analysis of the buildings and from the collection of data regarding consumption and energy waste, do not imply changes in the overall functional structure, or changes regarding the public property. The buildings is in fact public property (Palazzo d'Accursio is owned by the municipal administration) and in particular, this aspect is important as regards permitting procedures, which in some passages imply the adoption of internal approval acts.

1.1 The Italian legislations for the preservations on cultural heritage

The concept of cultural value derives from the fact that the building is a monument of exceptional value, bound under the National Law of Conservation of historical art and ethno-anthropological goods (Legislative Decree 42/2004).

For the building listed with this low, all work referring restoration, extraordinary maintenance and normal maintenance must be done with the approval of the local Heritage Preservation Authority that is an offshoot of the Italian Ministry of Cultural Heritage.

The approval of project is the basis for the second approval of local authority (Building Commission of Municipality of Bologna).

The preservation of the building is guaranteed by the Director of Heritage Preservation Authority of Cultural Heritage based on:

- Guidelines for the evaluation and reduction of seismic risk of the Cultural heritage (Directive 26/2010)
- Charter of the restoration of Athens (1931) and Venice (1964) and subsequent to that of Krakow in 2000;
- UNI 11182:2006 former NorMal 1/88 that allows the classification of the deterioration of stone materials.

1.2 The case study of Palazzo d'Accursio and its specific issues

The building, being considered of high historical and artistic value, must be subject to national standards of conservation and restoration and local urban regulation, and to the local sanitary regulations. Regarding the energy legislation, please refer to the Municipal Energy Plan (PEC), even if the buildings of such value do not have defined obligations.

The promoter of the Palazzo d'Accursio case study is the local government - the Municipality of Bologna - who is also the owner of the building. In addition to the City of Bologna the case study involved the following stakeholders: University of Bologna (project partner), Artemis (project partner), ICIE (supplying specialist guidance in the environmental energy improvement), IBC Institute of Cultural Heritage (architectural and environmental heritage field that carries out support to local authorities for the understanding, conservation and enhancement of the architectural and natural heritage), the Heritage Preservation Authority for the architectural and landscape goods for the provinces of Bologna, Modena and Reggio Emilia (Organisation approving the interventions to be implemented in the project).

In the case study of Palazzo d'Accursio consultation with the local government coincides, while it is maintained consultation with the Superintendent. This consultation takes place directly between the representatives of the two entities, with a view to analysing the applicability of measures to improve energy on buildings of cultural value.

On the other hand, it's necessary to point out that the Heritage Preservation Authority has been involved in the LCS team but, because of the role that it covers, it preferred to keep an independent position in relation to the project procedure, that entails the release of the formal authorisation to the making of the Palazzo d'Accursio extraordinary maintenance works.

1.3 The Local case Study Teams

The exact constitution of LCS-Teams is based on 3encult partner and Stakeholders listed below:

1. **Municipality of Bologna** composed by:
 - process responsible: ing. Fabio Andreon (executive Public Works Dept.);
 - scientific responsible: arch. Manuela Faustini Fustini (Cultural Heritage, Public Works Dept.);
 - arch. Arturo Todaro (Designer for extraordinary maintenance, Public Works Dept.);
 - p.i. Capuzzi Davide (Plant engineer expert, Public Works Dept.);
 - dott.ssa Pamela Lama (International relations and projects Office);
 - dott. Francesco Tutino (Environment and energy Dept.);
 - dott. Daniele Zappi (Environment and energy Dept);
 - arch. Federica Legnani (Old town planning).
2. **University of Bologna** composed by:
 - arch. Camilla Colla (non-destructive analysis and tests);
 - ing. Elena Gabrielli (non-destructive analysis and tests);
 - ing. Marco Giuliani (energy analysis and simulations);
 - ing. Francesco Ubertini (DICAM department responsible);
 - ing. Giacomo Paci (Wireless sensor networks).
3. **Artemis srl** composed by:
 - ing. Enrico Esposito (IR thermography tests and indoor monitoring);
4. **Icie – Larcolcos** Laboratory (supplying specialist guidance in the environmental energy improvement) composed by:
 - Arch. Valerio Nannini;
 - Ing. Sandra Dei Svaldi;
 - Arch. Mena Viscardi.
5. **IBC- Regional Institute of Cultural Heritage** (architectural and environmental heritage field that carries out support to local authorities for the understanding, conservation and enhancement of the architectural and natural heritage) composed by:
 - arch. Piero Orlandi
 - arch. Andrea Zanelli
6. **Heritage Preservation Authority office** for the provinces of Bologna, Modena and Reggio Emilia (Department for architectural treasures and landscape for the provinces of Bologna, Modena and Reggio Emilia. Organisation approving the interventions to be implemented in the project).composed by:
 - arch. Franca Iole Pietrafitta (project officer)
 - arch. Paola Griffoni (Heritage Preservation Authority Director)

2 The conservation aspects and energy saving actions for the “Sala Urbana” in Palazzo d’Accursio

2.1 The “Palazzo d’Accursio”

2.1.1 Local climate data

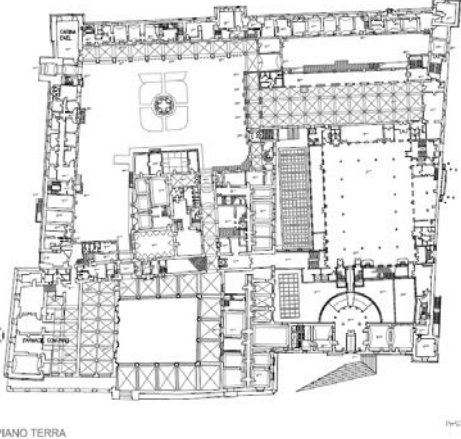
Local climate date	BOLOGNA
(building plan showing the north) 	Climate zone: E
	Climate area: 3F
	Degree days: 2.259
	Altitude: 54 m
	Coordinates: Lat N 44° 29' - Long E 11° 20'
	Average wind speed: 1,60 m/s (max 3,20)
	Prevailing wind direction: South/West
Winter climate data	Summer climate data
Winter design temperature: - 5°C	Temperature: dry/wet bulb: 33/22 °C
HR max: 95% (Nov.- Dec.)	HR: 43%
Heating days per year: 183 (15 Oct.- 15 Apr.)	Daily temperature range: 12 °C

2.1.2 Report on history of the building

The original nucleus of the building was the so called Biada Palace, used for the storage of grain. This has been then expanded over the centuries to become the institutional headquarter of the city. It was protected by walls and towers, located at the four corners of the quadrilateral perimeter, with entries in the middle.

The building has hosted different institutions and functions in several historical phases.

Since 1336 The Palace hosted the city Government, then the papal legation, and later on it testifies the Cisalpine Republic period.

Nowadays it is the seat of the city municipality and of prestigious Museums, such as the Morandi Museum and the Arts Municipal Collections, which houses paintings and furnishings from the Middle Ages to the 19th century.

The Palace is located in the historical centre of Bologna, in the core of an ancient formation where the original Roman *urbs* used to be. The northern view is towards the ancient Via Emilia (now known in that stretch, as via U. Bassi). Maggiore Square, on which the main facade of the Palace overlooks, is the hub of the public life in the city, where the public and religious festivities are celebrated.

Some information has to be given in order to sum up the additions and structural changes made over time, mostly repairs and renovations.

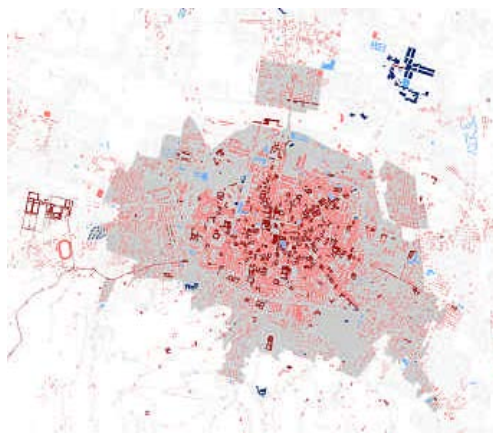

The actual structure of D'Accursio Palace is the result of several interventions, beginning with the construction of the original thirteenth-century nucleus of the so called Biada Palace, which was initially used as a corn deposit. It was protected by walls and defensive and lookout towers, which were located at the four corners of the quadrilateral, and at intermediate access points. Already in 1365, to defend his power, Cardinal Legate erected crenellated walls interspersed with towers. In 1425, following a fire, the part of the building that faces Maggiore Square was completed by the architect Fioravanti in a typical local late-Gothic style. In 1508, the walls were reinforced around the main nucleus with white and red merlons (the same colours of the city vessel). Inside, in the main courtyard, the western body of the palace was built with of a porch whose architecture was similar to the one of the previous century, and with a "ribbed" staircase used to let horses go

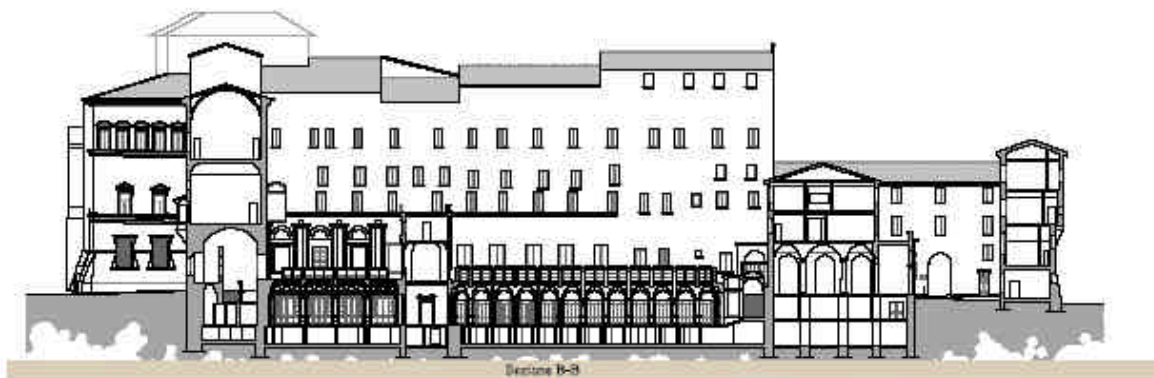

up to the second floor. In the phase between 1513 and 1796, when the city was ruled by a mixed government composed by a senate appointed by the citizens and a Cardinal directly designated by the Pope, the Palace hosted the apartments of the Cardinal Legate, one at the ground floor and another at the second, where a chapel was built during the second half of year 1500 by Galeazzo Alessi and then frescoed by Prospero Fontana. At the end of the sixth century, the building showed the consistency it has nowadays, apart from the area of the botanical garden, where the Stock room was built in 1886.

Therefore, the architectural style is obviously not homogeneous. The fourteenth part overlooking Maggiore Square has a very severe style without decorations. The fifteenth century part of the building has a different battlement and has marble mullioned windows. Everything is united by a large portal designed by Alessi in mid-1500 constituted by double pillars in sandstone with a statue of Pope Gregory XIII in the middle (reformer of the calendar). The sides of the palace are still closed as a fortress of solid bricks.

Some observations have to be done referring to the current constraints for the protection and preservation of the whole building, in particular for what is concerned with the transformability of space, and the possibility to change the structural solutions and plants network.

The building does not have any particular structural problem. The whole construction is in brick bearing walls with two or three heads of bricks. The building materials are typical of the area: as said, brick for the bearing structures (two or three heads), sandstone for the decorations and with some exceptions marble for the embellishment of the architecture, while the roof structure is entirely made of wood (beams, trusses..).

On the other hand, there are some problems for the management of the plants network due to the antiquated status of these.

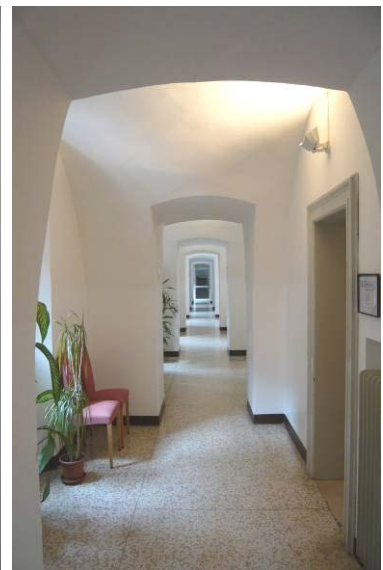

This is the proposal addition of buildings that characterize Palazzo d'Accursio from the origin until now. This reconstruction is based on the thesis described from Hans W. Hubert in "DER PALAZZO COMUNALE VON BOLOGNA" 1993 Bohlau edition.

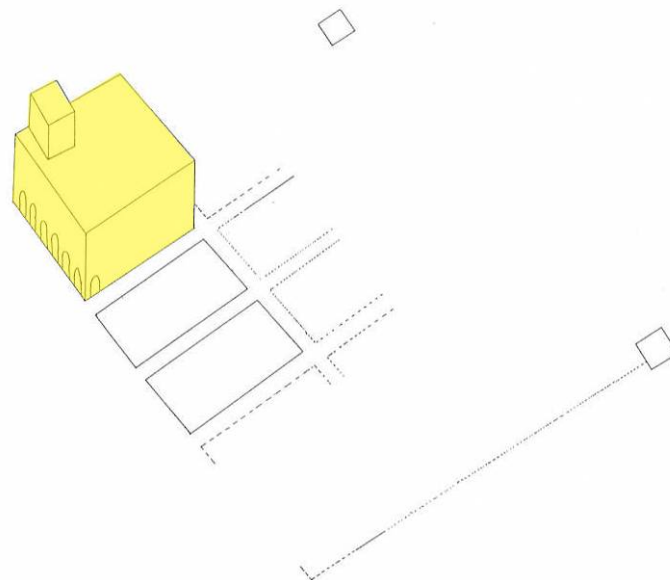

Palazzo della Biada in 1295 (Origin of Palazzo d'Accursio)

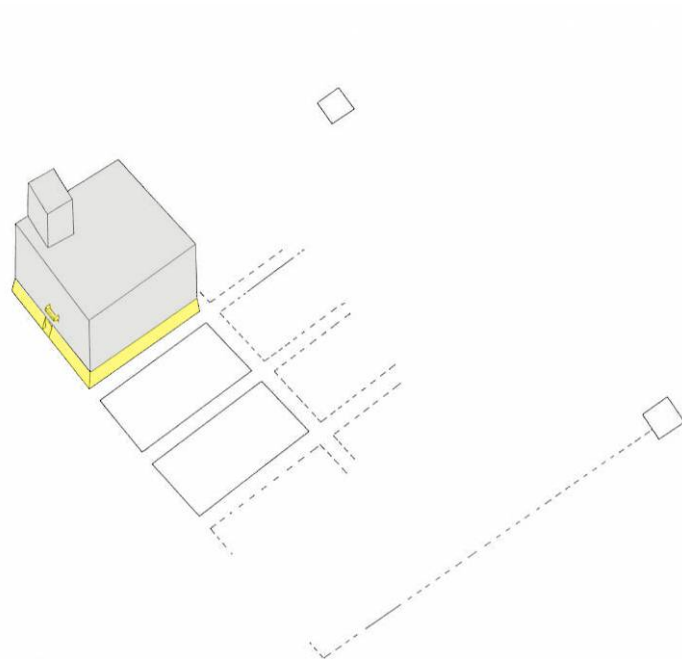

Palazzo della Biada in 1336 (First addition)

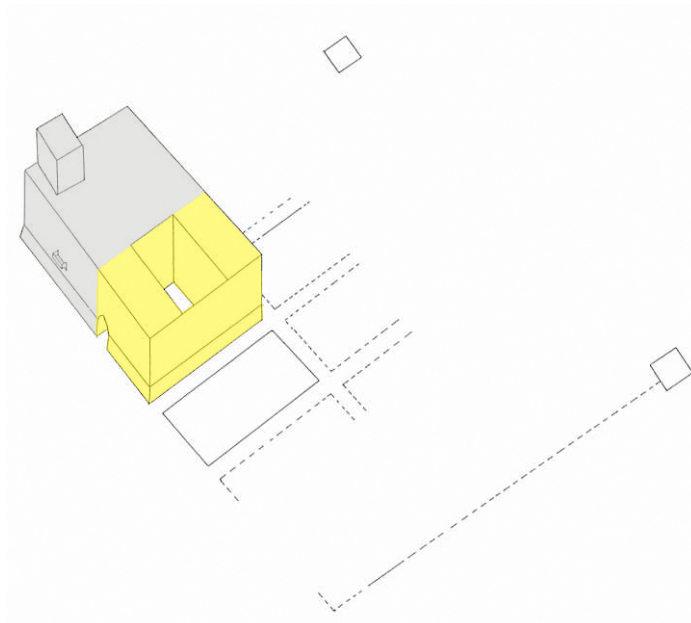

Taddeo Pepoli's Palazzo Grande in 1340,

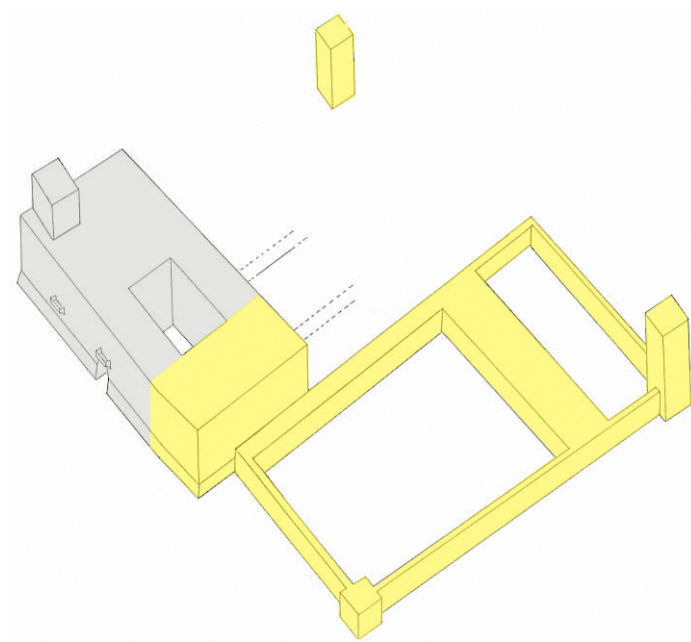

Palatium Apostolicum des Andrion de la Roche at 1365

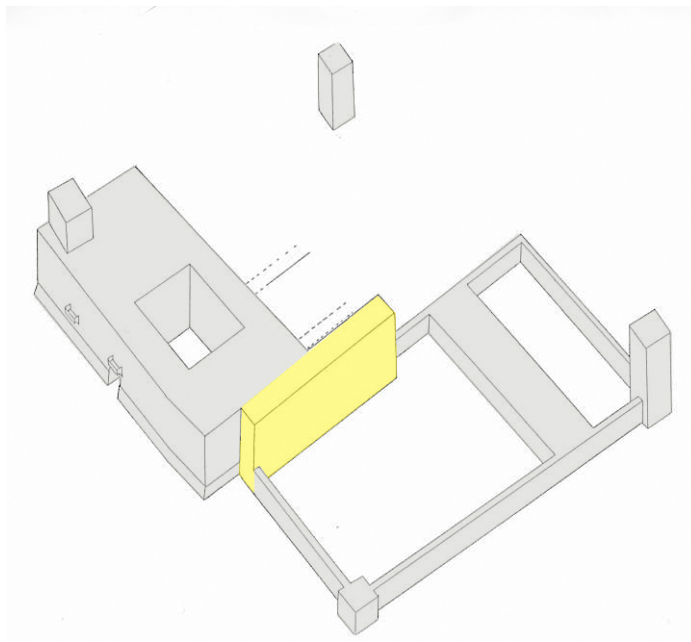

Palatium Apostolicum and your first extension in 1425

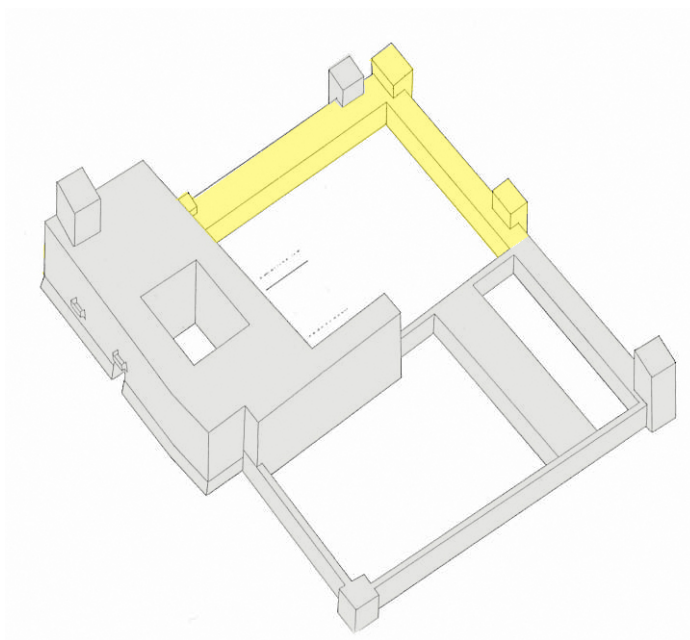

Palatium Apostolicum with Cortile degli Svizzeri in 1436

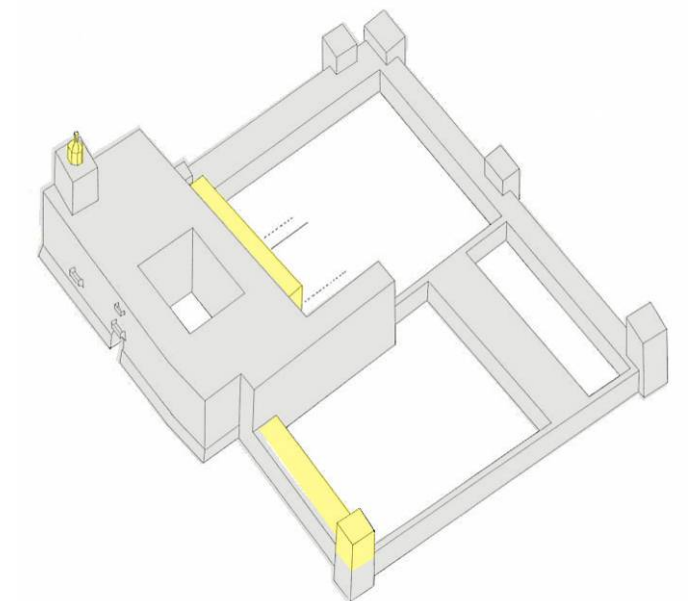

Palatium Apostolicum in 1513 defined also as Giulio II's Palace

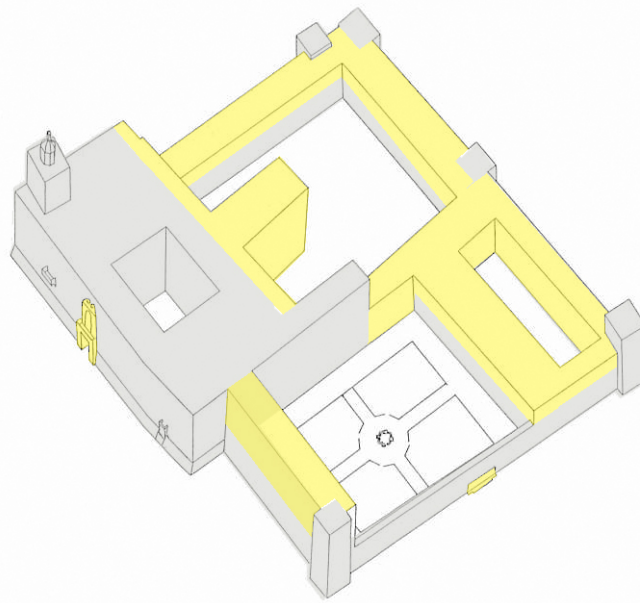

Palatium Apostolicum in 1585

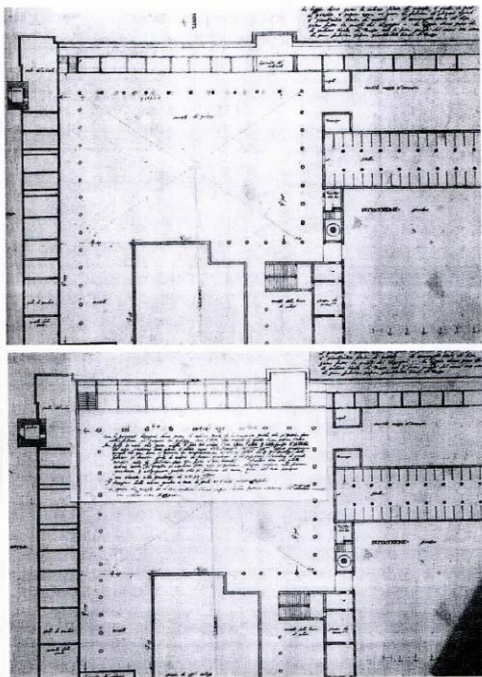









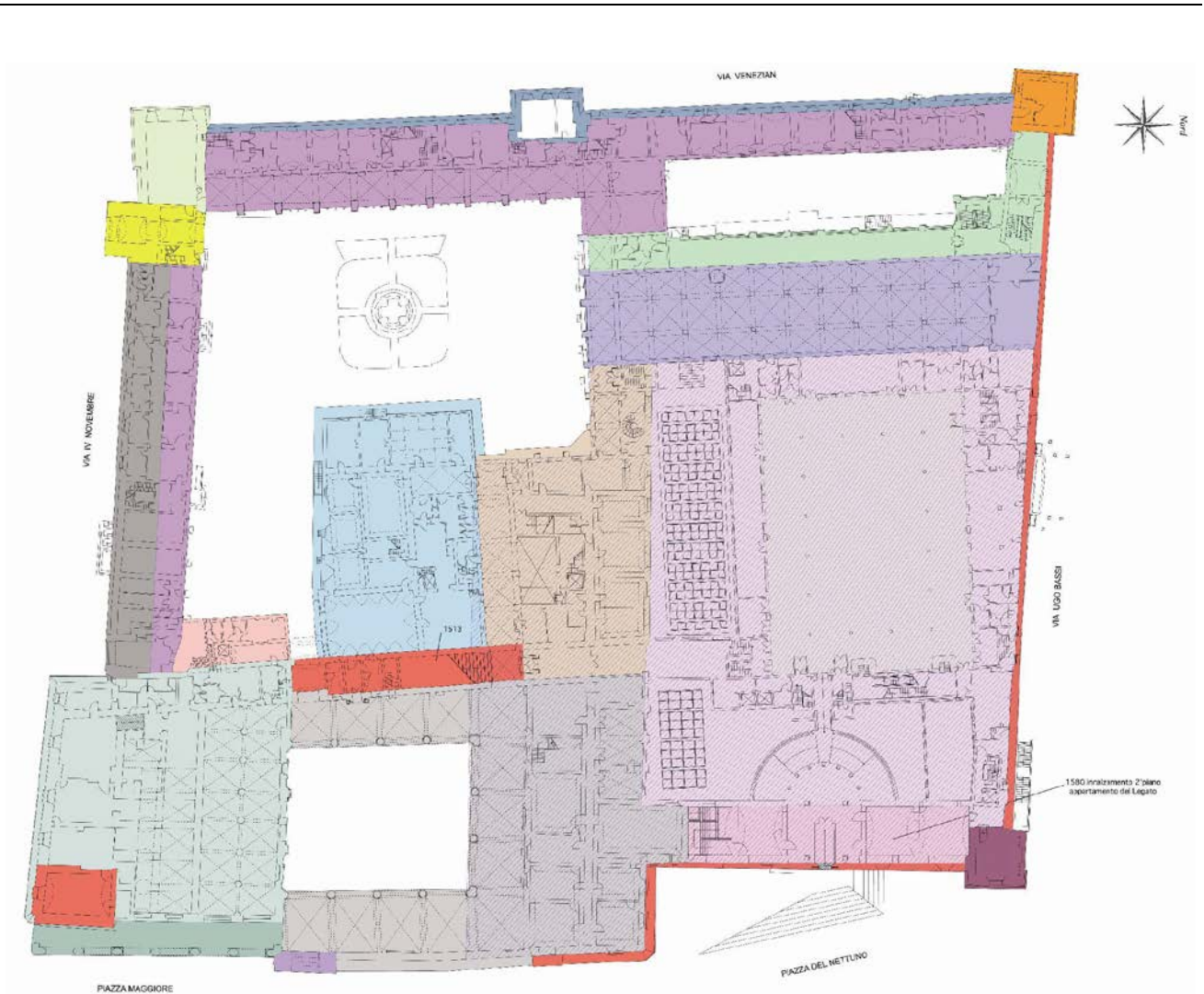















Project drawings by Pietro Fiorini made between 1606 and 1611 for the completion of the rooms that were supposed to host the Swiss soldiers.

Historical summary table

History of the buildings			
Construction phases	First phase of construction:	1295	Original nucleolus of the Building (Palazzo della Biada)
	Second phase of construction (first extension):	1340	Palazzo Grande di Taddeo Pepoli
	Third phase of construction	1425	Palatium Apostolicum (1365-1425) Construction of the crenellated walls interspersed with towers
	Fourth phase of construction	1436	Construction of the Cortile degli Svizzeri. Reinforcements of the walls
	Fifth phase of construction	1513	Completion of the cardinal lagate apartments (fistrs and second floor)
	Sixth phase of construction	1585	Construction of the buildings around the Cortile degli Svizzeri
	Seventh phase of construction	1886	Construction of the Stock room in the area of the botanical garden named Sala Borsa
Restoration phases	First restoration	1885	Palazzo della Biada front restauration
	Second restoration	1933	Restoration front with the substitution of old windows
	Third restoration	1936	Realization Municipal collections inside to Giulio's palace
	Fourth restoration	1939-1943	Restoration ovest front

On the next page will show the floor plans in advance by a plan color on the various phases of construction of the buildings.



	XII secolo Torre Accursio		XVI secolo prolungamento costruzione ala Fioravanti		1830 - ingresso da via Ugo Bassi
	1250 - Torre dei Lapi		1513 - Torre Canton de Fiori		1874 - restauri sulle facciate di Piazza Maggiore
	1312 - Torre di via Venezian		1513 - scalone Bramante, innalzamento Torre Accursio, estensione mura di protezione		1876 - apertura ingresso
	1336 - Palazzo della Biada		1551 - scuderie		1883 - Sala Borsa
	1352 - Torrione angolo sud		1580 - portale Alessi		1885 - restauri sulle facciate di Piazza Maggiore
	1365 - Mura lato sud		1585 - innalzamento edifici a ridosso mura a servizio dei cavallegge		1883 - Sala Borsa
	1429 - costruzione progetto Fioravanti		1588 - nuova ala a ridosso dello scalone		1885 - restauri sulle facciate di Piazza Maggiore
	1436 - mura di protezione lato ovest		1716 - lavanderie		

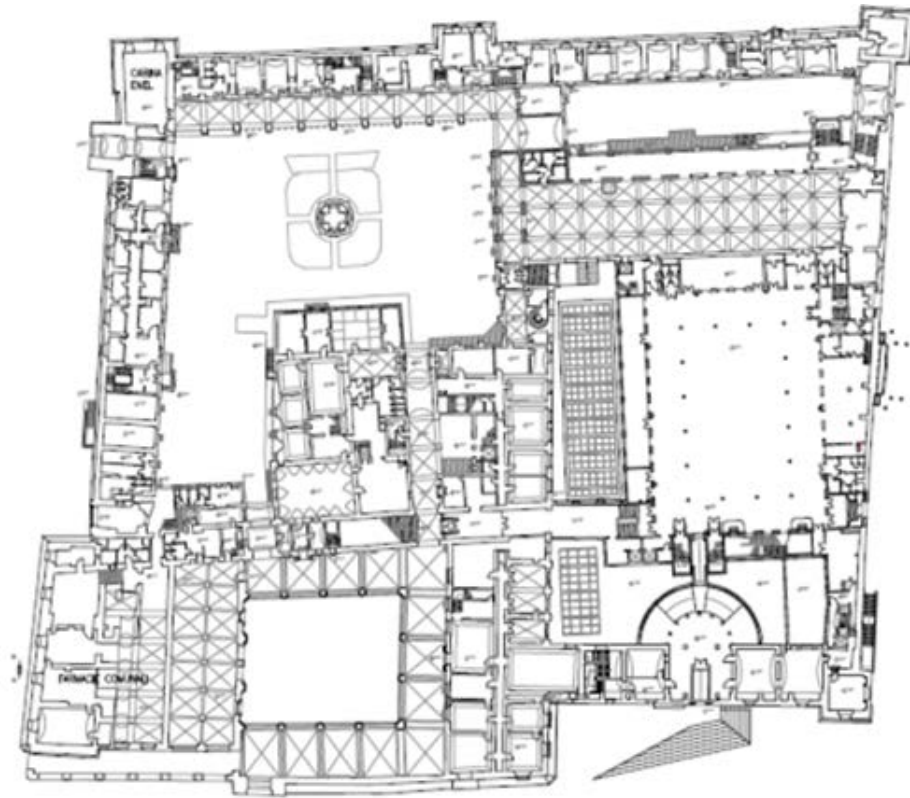

PIANO TERRA

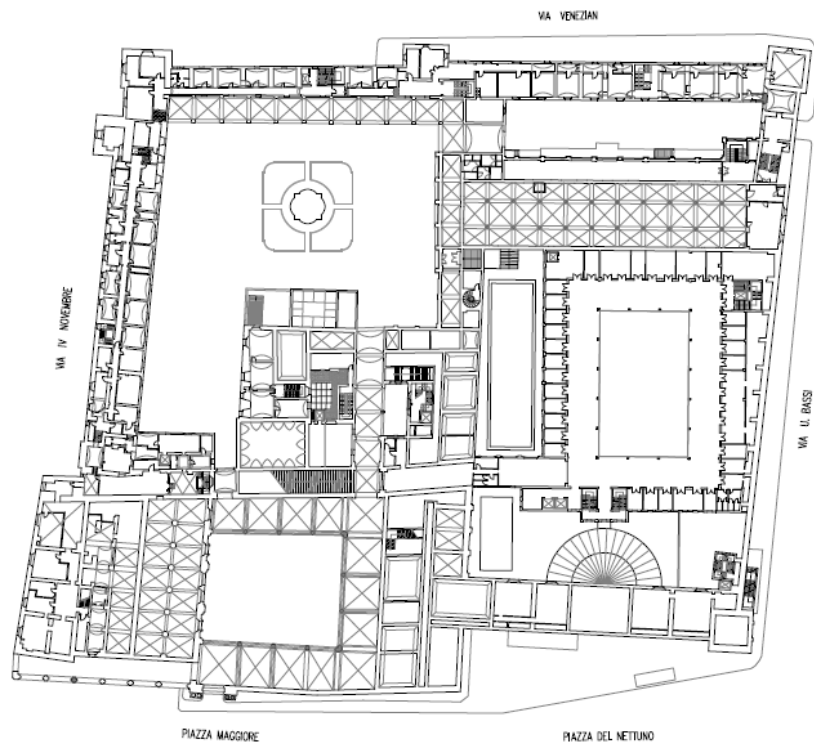

PIANO PRIMO TRAPIANO

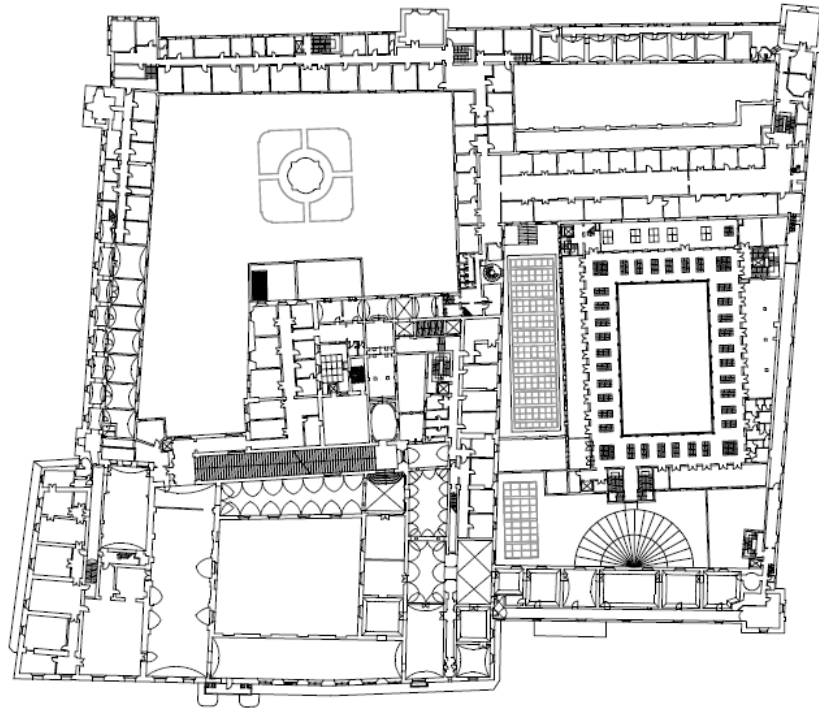

_PIANO PRIMO

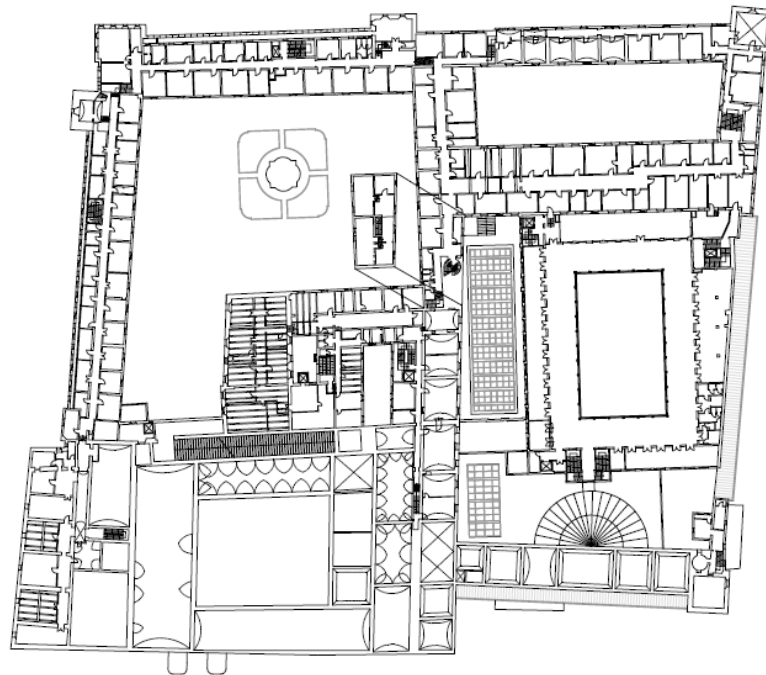

_PIANO SECONDO TRAPIANO

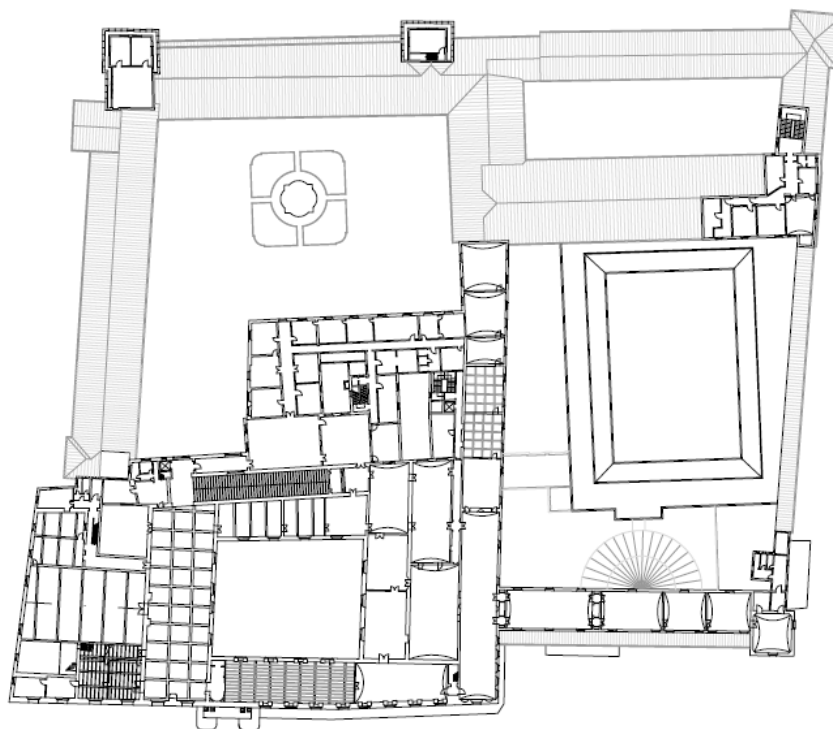

_PIANO SECONDO

2.2 Constraint and protection conditions

2.2.1 Principles of protection given by the Authority for Cultural Heritage

Precise indications about the type of renovation admitted for buildings of historical and architectural interest are given in article n. 25 of the Urban Building Regulation Code. In particular the interventions can be:

- the renovation of the architectural features and the restoring of altered parts: renovation of outer facades or interiors, philological re-construction of eventually missing parts of the building, conservation or restoring of shared spaces like courtyards and gardens;
- the consolidation with substitution of un-repairable parts without modifying the position and height of major walls, lofts, ceilings, stairs and roofs (with re-making of the original roof covering);
- the removing of elements that have been recently added or are incoherent with the original scheme of the building;
- the insertion of essential technological and sanitary installations, respecting the previously given constraints.

The building is qualified as *building of historical and architectonic interest* in the Urban Building Regulation Code, and therefore admits only respectful interventions of renovation and maintenance. The typologies of intervention and modification admitted are described at the art. n. 57 of the Building Regulation Code, specifically with requisites nr. IS 1, 2, 3.

In particular, the Regulation Code prescribes to preserve the original integrity of every architectonic, artistic and decorative element of it.

For the preservation of original characters of the building, the limitations, given by the requisite IS nr. 1 of the Code, are the following ones:

- to preserve and conserve the building roof in its original shape and consistence, and this concerns specifically interventions like the insertion or addition of chimneys, skylights, gutters or pluvials; in particular, in the conservation of the original shape of the roof, every new component put in substitution must have the shape and colour of the previous original one.

- roof insulation and ventilation must be extended to the whole roof surface, keeping the thickness inferior to 20 cm, eventually rising the roof's height;
- to insert small chimneys for airing in order to conserve the original shape of the roof, putting them close as possible to the roof top, avoiding products made of cement, fibre – cement, or plastic ;
- to keep the technological installations for the reception of signals (like parabolic antennas for TV/Earth satellite signals) within the number of one for building, placing them inside indoor locations or on secondary pitches;
- to satisfy the need for lighting of every indoor room, avoiding the opening of slots in the roof pitches, using only skylights, keeping these aligned to the existing ones, at a distance of at least 1,5 m from the gutter's line;
- to keep the gutters and the pluvial in good conditions: in case of substitution, products made of plastic or zinc laminate must be avoided;
- To keep the original shape and design of every façade: this concerns specifically the opening of new windows or the changing of the dimensions of the existing ones, the making of terrazzo, balconies, bow-windows or façade chimneys which is avoided for all the facades facing external public spaces. Only the re-opening of previous existing windows is permitted. Modifying existing openings is allowed only if the façade overlooks minor patios or backing spaces and if it collaborates to the rational reordering of the façade image.
- The impact on the façade of the positioning of electrical wirings must be reduced as far as possible; the wires and the installations components must be hidden in every possible way, as far as the norms on safety allow it, by locating them inside the building or under the paving of the street or the one of the porch, When on main facades, they should be aligned and positioned in order not to interfere with decoration or painted parts. It is avoided to install heat pumps, boilers, air conditioners, or motor condensing units on roof pitches, on main facades and under porches.
- To extend the maintenance of original plasters and superficial coatings to every coated façade of the building, in order to preserve them as they were.
- To keep the original window infixes and shading elements in every external perimeter wall. In case of substitution, which is admitted only if the original components cannot be repaired, the new inserted elements must have the same partition, material, colour and shape of the previous.

Then, for the preservation of the historical characters and of the original indoor distribution scheme of the building, the constraint, expressed by the requisite IS n.2 of the Code, prescript to maintain the original status;; In particular:

- adding new dividing surfaces is allowed only if they do not interfere with the façade's openings;
- original dividing walls, even the secondary ones with no structural function, with architectural value or original decorations, original garrets or suspended ceilings with historical value must be maintained and renewed;
- New lofts located inside the rooms must be fixed to the opposite wall facing the external one with windows and openings, at a distance of at least 2,40;
- The whole area of the new single rooms located inside the historic building can't exceed the 30% of the whole area of the building;
- new rooms can be located in the under-roof space only in case the electrical installations and wiring needed do not interfere with existing elements of architectural and historical value;

The constraint for the preservation of external and open spaces of historical buildings, given by the requisite IS n.3, prescripts to keep the original organization and conditions of gardens and courtyards. Therefore:

- the installation of service lifts, anti-fire stairs or elevators, which cannot be done by means of enclosed volumes, is permitted only in minor courtyards and patios, on minor architectural value facades, positioning them outside of the optic cone of the inner major rooms or entry porches.
- The ecological balance of gardens cannot be altered.
- Original garden pavements and furniture must be maintained in the original conditions.

2.2.2 Limits and prescriptions determined by the Owner

In 2010, the Municipality adopted an internal regulation for the use of municipal halls, both by private bodies or associations, and by the same administration. Such regulation lists those Palace halls that can be used for hosting public events, whose compatibility must be coherent with the structural and monumental characteristic of the place. Inside these halls, it is not possible to assemble structures which differ from those already present and it is not allowed to place food services of any kind. The use of the halls is affected by all the applicable safety standards and at night the constant control of the access should be guaranteed.

2.2.3 Limits and prescriptions arising from Area Regulations

According to the Emilia-Romagna Regional Law, the Structural Plan of Bologna (PSC) has listed Palazzo d'Accursio as one of the "buildings of historical and architectural interest" (edificio d'interesse storico architettonico). Some of those buildings are also listed by the national law. The PSC has set the aim of the preservation (to maintain the value of the buildings of historical and architectural interest in the urban context or in the landscape) and some rules for any interventions and change in use. Any kind of intervention that involves those buildings which are also listed by the national law (like Palazzo d'Accursio) must be allowed by the authority for the preservation of the cultural heritage.

Therefore every action or use modification involving the buildings only listed in the PSC must respect the restoration criteria set. For more detailed rules, the PSC refers to the Urban Building Regulation (Regolamento Urbanistico Edilizio).

2.3 Selected area of intervention

If building as a whole is composed of different building blocks, you can break down the analysis for different functional area.

The diagnostic tests and the case study will be concentrated in certain significant "nodes" in the Municipal Palace, based on the following criteria:

- mixed construction features;
- presence of critical issues in the management of the thermal control according to the different "uses" inside the building;
- different construction age.

2.3.1 Functional Area 1 - Municipal Collections (2nd floor)

Selected area is dedicated to the art collections of the city with paintings and furniture related to different ages. This area has the problems related to the maintenance of movable goods kept inside, with critical issues related to the hygrometric control and mixed construction characteristics.

Functional area consistency 1: Municipal Collections		
Functional area 1: Municipal Collections	Height interpolated average net (m):	6,51 m
	Surface area (Gross/Net) heated (mq):	1.073,69 m ²
	Volume (gross/net) heated (mc):	6.990,76 m ³
	Opening to the public (from/to; hours /day; temperature set-up):	09:00-18:00

	Hours of working (from/to, hours/day; temperature set-up):	Monday-Sunday 06.30-18:00
	Hours of air conditioning (from/to; hours/day; temperature set-up)	No air conditioning

Functional area consistency 1 : Municipal Collections				
	Years	Gradi Giorno (GG)	Consumption (l)	Consumption (kWh)
	-season 2007/2008	2.162,8	16.179	155.353
	- season 2008/2009	2.238,1	13.133	126.107
	- season 2009/2010	2.405,7	14.381	138.087
	- season 2010/2011	2.130,1	14.629	140.466

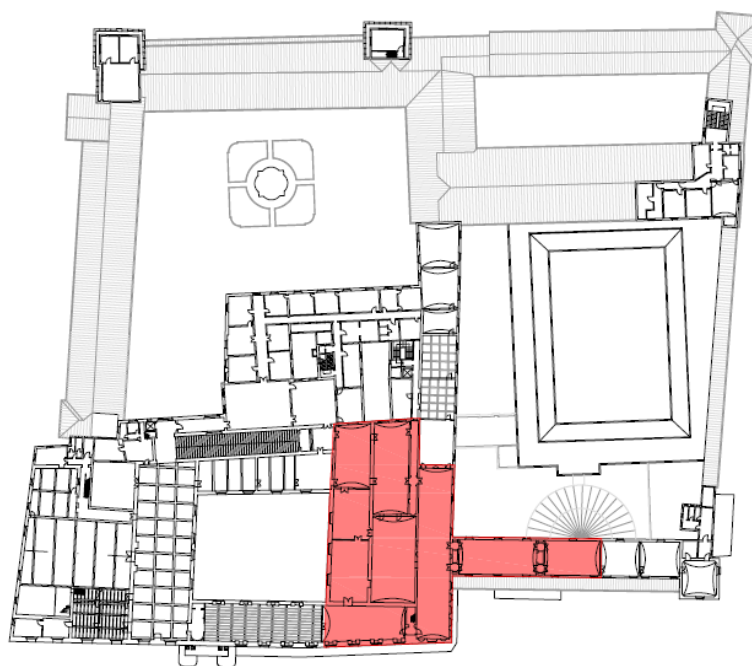

PIANTA PIANO SECONDO

■ Area oggetto di PHPP

2.3.2 Analysis and monitoring results (status pre-intervention)

The project has been developed, where possible, by non-invasive and completely reversible diagnostic and monitoring analysis to increase the level of knowledge of the building and to assess its performance, through:

- GPR radar tests
- Infrared Thermography (IRT)
- Blower door test
- U-value determination
- Monitoring through WSN

2.3.3 Design Builder applications results (current status of the building)

An Energetic Analysis of the most significant spaces with the aim of experimenting the use of the software Design Builder (an informatics tool for the energetic analysis in dynamic conditions developed with the ENERGY PLUS engine) that will be used in the Project.

- **The energetic model of the Municipal Collections Area**

The basic steps we referred to for the elaboration of the energetic model and for the project analysis are the following:

- building's geometry and openings modeling;
- creation of thermal zone;
- insertion in the model of shadows generating elements;
- geographical location of the building and local climate and weather data loading (in the Tab "Location");
- assigning to the building's surfaces and external enclosure its physical characters (given in the Tabs "Construction" and "Glazing");
- adding the thermal charges and correspondent schedules (in Tab "Activity");
- definition of the installations characters (in Tab HVAC).

1st step

As the aim of this study is to evaluate the energetic performance of the wing of D'Accursio Palace hosting the Municipality Collections, we proceeded to re-build the examined area extracting from the rest of the model the Museum spaces to be analyzed, considering the walls facing other Museum spaces with the same temperature, oriented towards the heated spaces adjacent to the simulated building, as if they were adiabatic.

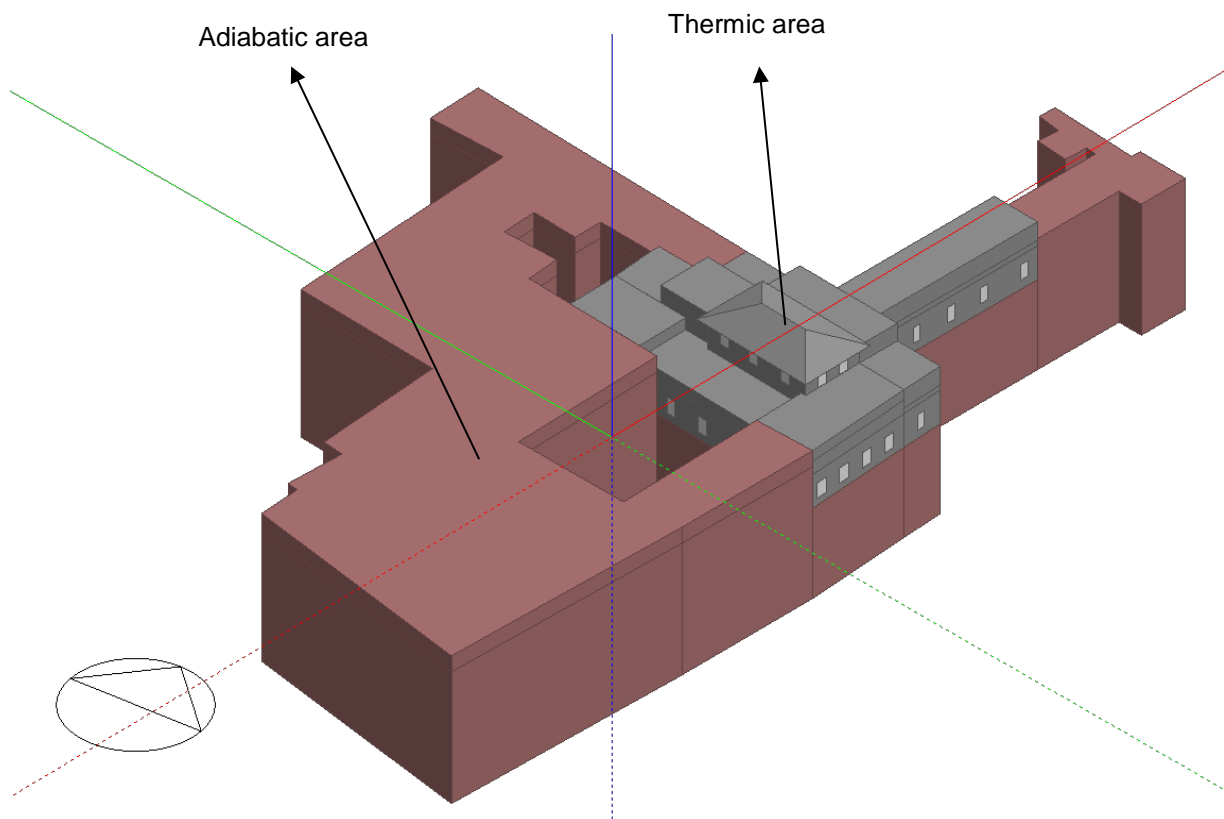

Energetic model of part of “D’Accursio” Palace

2nd step

Four thermal zones were defined (same for the Blower Door Test) with the same use profiles, with the same identifying names of the rooms:

- Room 19-20
- Room 2-3-18
- Room 4-5-6
- Room of the Sala Urbanas

The last one is actually closed to the public because of roof infiltrations.

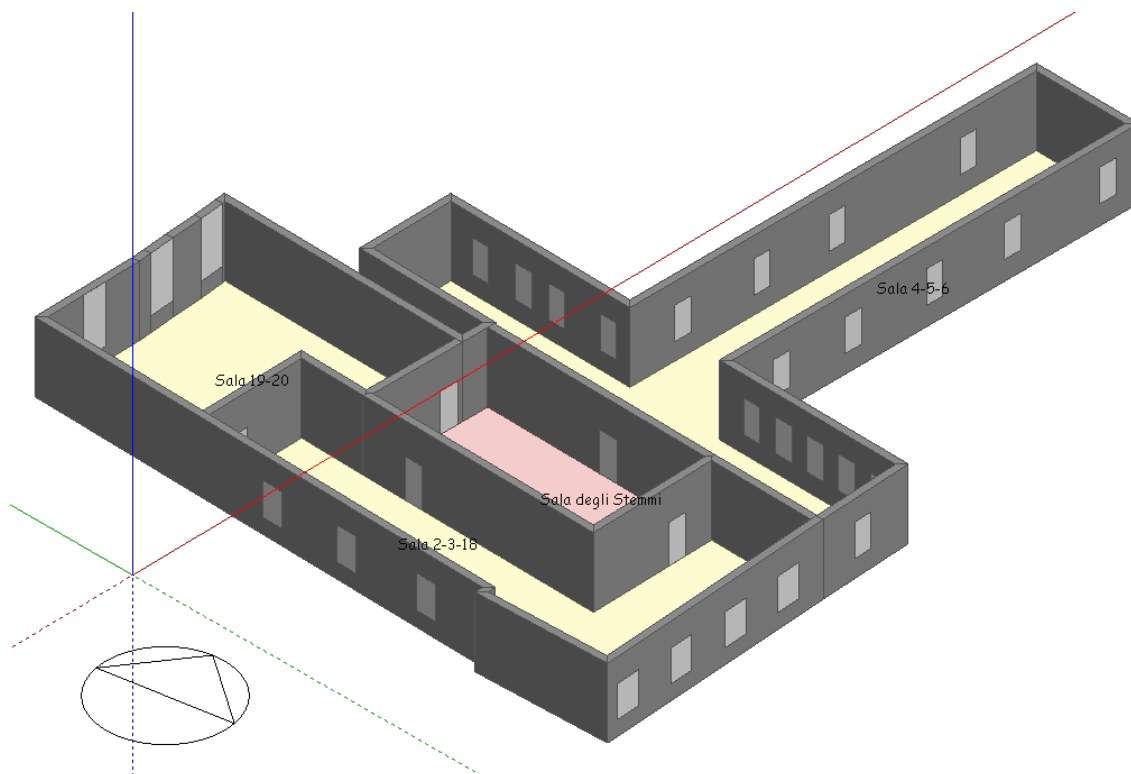

Thermal Zones of the Municipal Collections

3rd step

The non thermal blocks were added, in order to provide shadows to the analyzed volumes, in order to evaluate correctly the effects of shadows brought by other buildings. Then other intermediate areas like attics were inserted, as a separation between the indoor thermal zones and the outdoor environment with a much lower temperature.

4th Step

Then we proceeded to reproduce the external context of the building, loading the weather data that corresponds to Bologna and setting the alignment on North, essential for the solar analysis of the model (latitude, longitude, height).

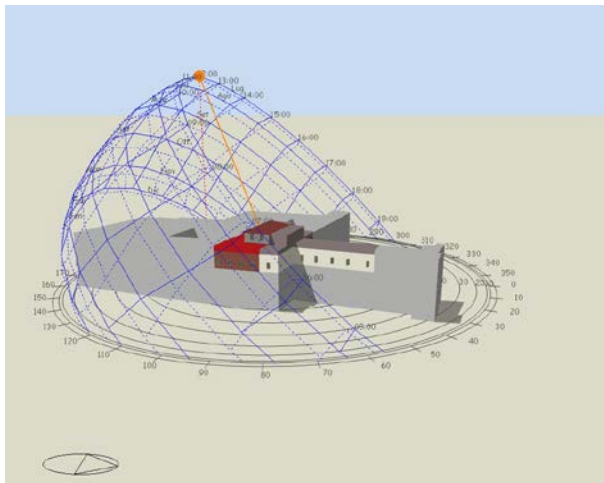

Solar axonometric 21/06/2012

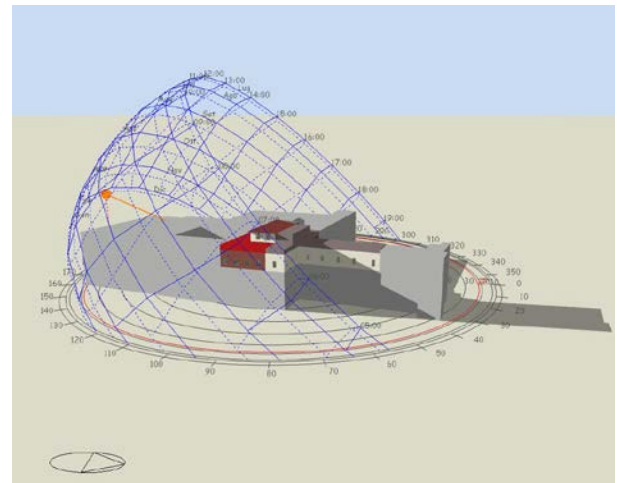

Solar axonometric 21/12/2012

Solar analysis at summer and winter equinox

The other information given in the weather data file are necessary for the dynamic energetic calculation, such as the solar radiation, in its direct and horizontally diffused component, temperature, relative humidity and wind speed.

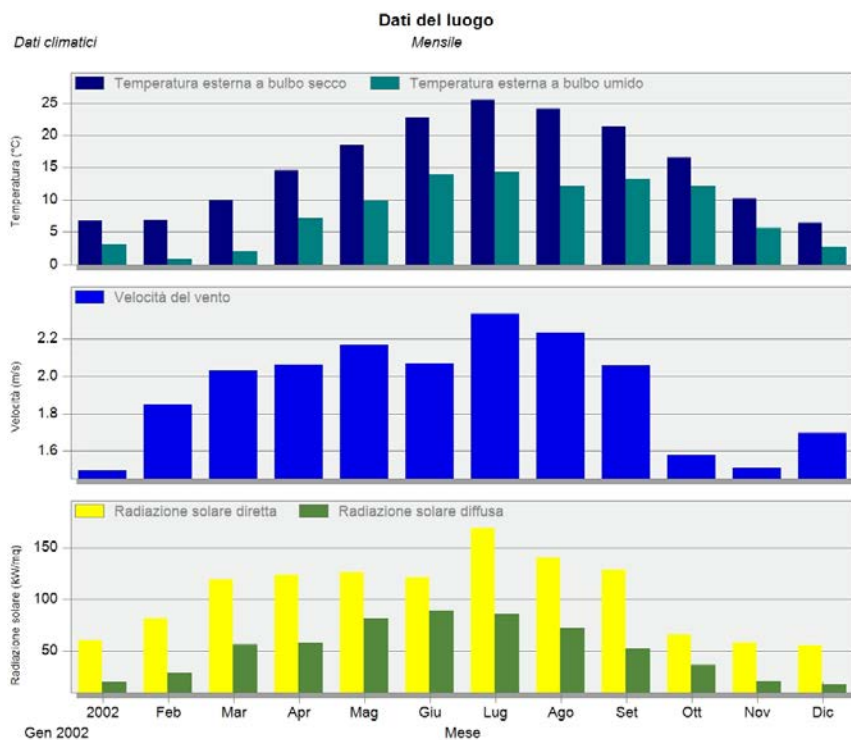

Bologna Weather data

When doing the dynamic modeling, it's quite common refer to IWEC data (International Weather for Energy Calculations) taken from Energy Plus database, which was elaborated among 1960 and 1970. But in this case we used weather data taken from the weather forecast station of Bologna, in order to obtain a simulation that considers the last decades climate changes.

5° Step

The following step was defining in detail the thermal and physical characters of the several building components (walls, ceilings, pavements, shutters) using the information given by the present study; in particular for the solid components, the necessary materials have been virtually rebuilt, defining the relative physical properties such as conductivity [w/mK], specific heat [J/kgK] and density [kg/m3].

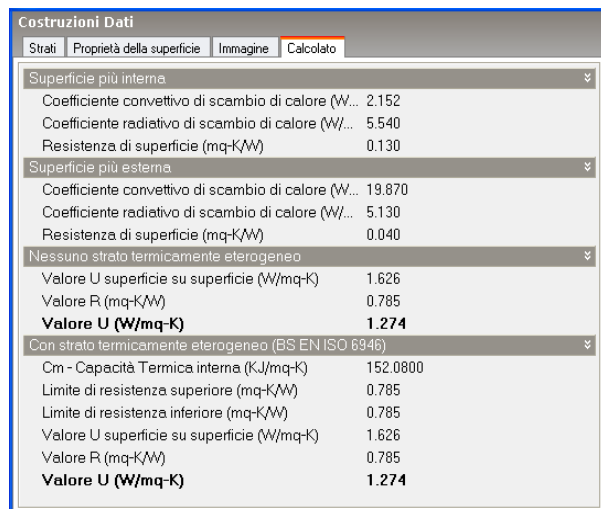
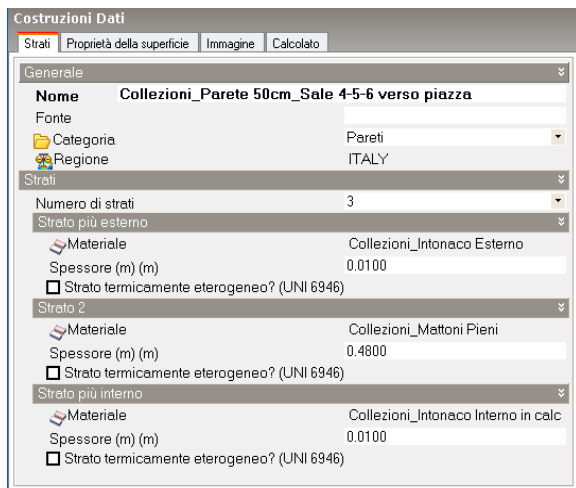

For the elaboration of vertical solid components (walls), and of the transparent (window shutters and glass) components, re-built in the Tab “Glazing”, we used in particular the Data given at point 3.1.2.1 of the present study “Survey of the external walls - Municipal collections”.

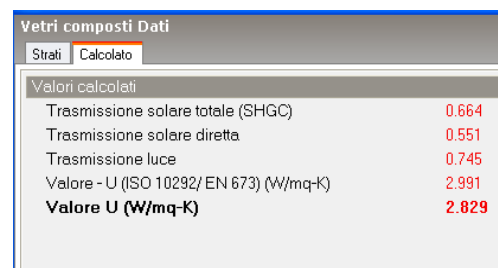
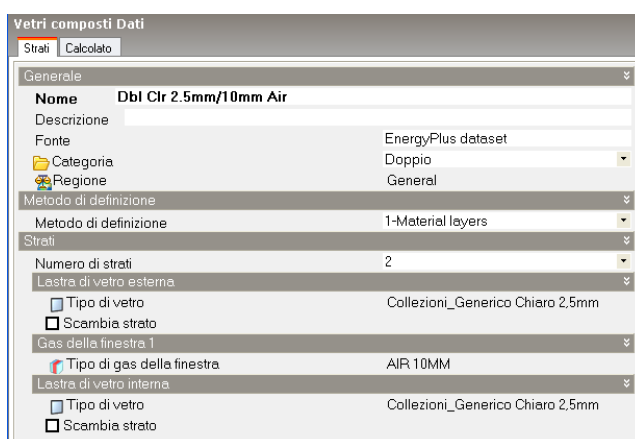

In Tab “Construction” has been defined the infiltration index (ACH-Air Change per Hour) which considers eventual cracks in walls and in windows.

These values have been defined using the equation about the Infiltration Air Change Rate used in the “Ventilation” Tab of the PHPP, in respect of the norm EN 13790:

$$\text{infiltration} = n_{50} * e \text{ coefficient}$$

where:

- n_{50} is obtained from the results of the Blower Door Test analysis
- e represents the wind control coefficient according to the norm EN832, considering in particular the value corresponding to the historic center zone (0,04) taken from the following table:

Coefficient e for Screening Class	Several Sides Exposed	One Side Exposed
No Screening	0.10	0.03
Moderate Screening	0.07	0.02
High Screening	0.04	0.01

Using the Blower Door Test results, the following “infiltration air change rates” are obtained

Tipo di zona	Risultato Blower Door Test (n_{50})	Tasso d’infiltrazione [vol/ora]
Sala 19-20	2,38	0,10
Sala 2-3-18	14,69	0,60
Sala 4-5-6	4,40	0,20
Sala Urbana(17)	2,52	0,10

But these values do not consider the infiltrations coming from the spaces connecting the room to the adjacent ones; in order to consider these contributions, each previously found out value has been increased of 0,2 vol/h.

The final results, therefore, are the following:

Zone Type	Tasso d’infiltrazione [vol/ora]
Room 19-20	0,30
Room 2-3-18	0,80
Room 4-5-6	0,40
Sala Urbana (17)	0,30

6th Step

At this step we developed the description of the activities, the spaces use profiles and the defining of the internal electrical and thermal pressures and charges. Then we put these information in the Tab “Activities”; the data requested by the software are the following ones:

- the occupation, derived by the ratio between the number of users and the floor area (people/square meter)
- the metabolic index of occupiers which expresses in quantity (measured W for persona) the intensity of the activity developed in the analyzed spaces , set on 140 W/persona (data derived from the Design Builder Data banking).
- The clothing index, for which were considered standard values of 1,0 clo in winter and 0,5 clo in summer.
- The consuming of sanitary warm water, absent in this Museum zone;
- The control temperatures of the indoor environment for heating (20°C), as well as for cooling (26°C);
- The internal contributions for air conditioning and electricity equipments and installations (in the Tab “Activity”, as well as the ones used for lighting (in Tab “Lighting”)

- **The results of the energetic analysis**

Using the Design builder Software we calculated the solar gains, the internal gains, the energy losses through the building external enclosure body and for ventilation, both in winter and summer time.

The analysis of energy need for heating has been developed for winter time and the energy need for cooling and lighting has been done referring to summer time.

- **Results of the dynamic simulation for winter season**

The results are shown as a synthesis of winter and summer season, they refer to the whole period with a monthly frequency, and to the building as a whole unit.

Losses



Losses through the building external enclosure body (whole period)

Contribution

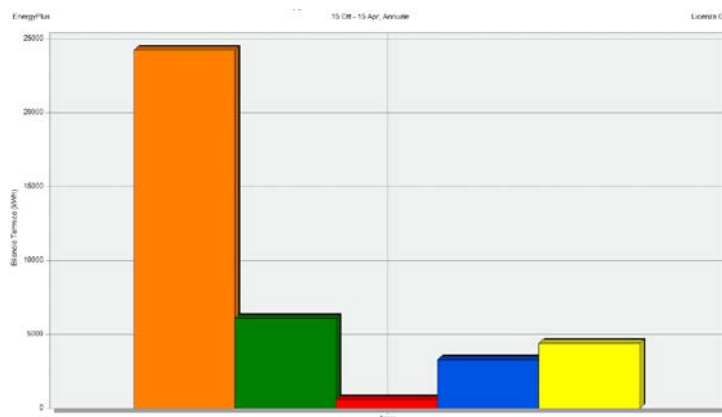

Contribution through the building external enclosure body (whole period)

The highest level of loss is due to external infiltrations caused by:

- the low thermal performances of the window shutters made in wood frames without seals;
- the thin interface between window and mobile frame and between fixed frames and the walls;
- the presence of installations going through the perimeter walls;
- the presence of cracks among the beams of the superior wood coffered ceiling

The rest of the gains has a minor role, especially the low contribution of the window walls due to the minor surface that they offer to the exchange with the outside. Among the free gains, those due to normal attendance and lighting assume a more significant role.

The total consumption of primary Energy for heating, resulting from the analysis done with this software can be estimated in 91.325 kWh, corresponding to 102 kWh/mq.

In the Tab below are reported the electricity consumptions due to equipments for air conditioning and for lighting.

Electric Energy Consumptions	kWh
Lighting	30.695
Air conditioning equipments (small stove)	6.635
Total	37.330

- **Results of the dynamic simulation for summer season**

In the following pages are shown the results referred to the whole year period in detail with a monthly frequency.

Whole year period

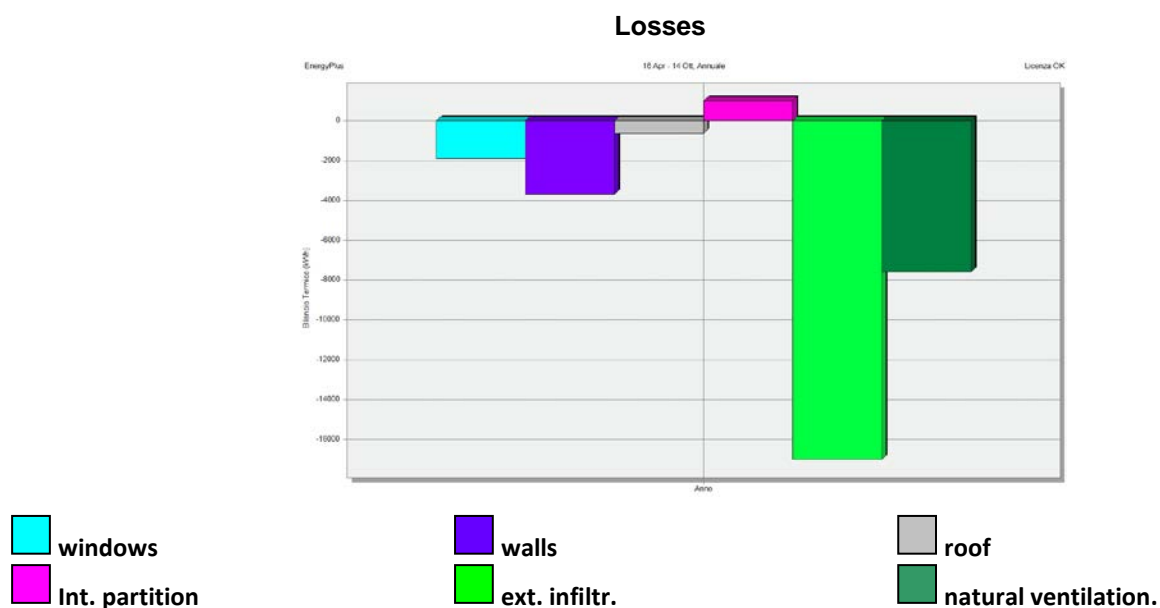

Losses through solid and transparent surfaces (whole year period)

Gains

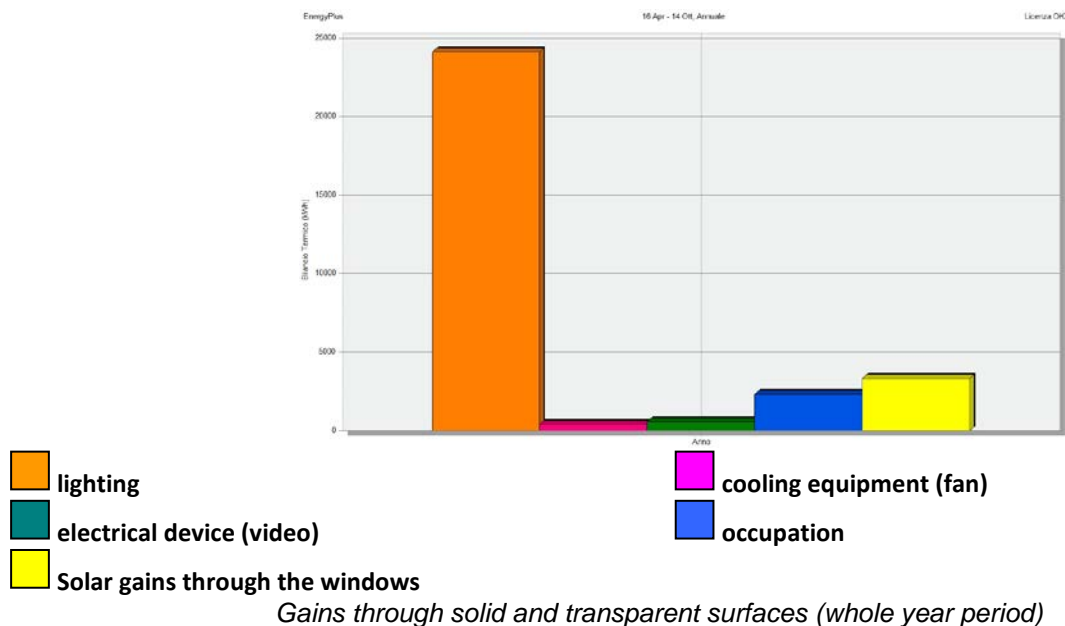

Below are reported the consumptions due to electric and air conditioning equipments

Electric Energy consumptions	kWh
Lighting	30.540
Air conditioning equipments (fan)	954
Total	31.494

2.3.4 Energetic retrofit proposal for Sala Urbana

The energetic retrofit proposal of Palazzo D'Accursio's "Sala Urbana" of the Bologna Municipal Collections was originated by the willingness of the Local Authority to integrate an intervention of extremely necessary non ordinary maintenance of the Room, vital in order to resolve the ceiling's frescos decay due to the rainwater infiltrations through the deteriorated roof covering, with energetic refurbishment interventions able to respond properly to the double requirement of improving internal comfort the Room – where there is no air conditioning - during the winter and summer period while protecting the fresco decorations on the walls and ceiling from direct sunlight by reducing massively the ultraviolet radiations and providing protection from the infrareads.

The energetic retrofit interventions that have been evaluated in order test their capacity to fulfil the given targets, considering the present constraint conditions, are the following:

1. Windows substitutions;
2. Insulation of the interior covering ceiling from the extrados of the roof ;
3. Roof refurbishment;
4. Plaster remake;

These interventions have been varied in different procedures, each one essentially corresponding to a different specific choice of the materials to be used in order to build up the technological packets and abacus. Follows a detailed description of the hypnotized interventions.

- **Windows glass and frames substitution**

The first intervention considered is the substitution of the present windows and window frames.

The Room does have nr. 10 window frames: 3 + 3 in the North and South facing facades and 2 + 2 in the East and West facing facades. The window frames in the East and South facing facades are adjacent to the exterior and do present a second external window frame of the same typology.

The window frames in the West and North facing facades, instead, are adjacent to the roof attic of other rooms of the Municipal Collections and are single.

The present windows, provided with a simple wooden frame and a single glass 2 mm thick, are in an evident state of decay. All the windows do have internal curtains in clear color.

The application of wooden/aluminum frame window frames (in laminar pine with the internal surface varnished in dark brown color and the external in aluminum varnished in dark brown color), with $U_f = 1,372 \text{ W/m}^2\text{K}$ associated to different “glass packets” was considered as option.

In particular, the choice was to analyze the effects obtained through the application of :

- 1) A triple glass 3 + 3 be/12argon/3 + 3be (offered performances: $U_g=0,7\text{w/m}^2\text{K}$ and $g=33$);
- 2) A double insulating glass 5 + 5be/16argon/4 + 4 (offered performances: $U_g=1\text{w/m}^2\text{K}$ and $g=27$);
- 3) A double insulating glass 4 + 4be/16argon/4 + 4 (offered performances: $U_g=1\text{w/m}^2\text{K}$ and $g=26$);

In every option was taken in consideration the use of low emission and solar control glass, that is with a good solar factor, “g”, pursuing the target of protecting the fresco decorated walls; the third solution involving the use of a selective glass that permits also to tear down the UV radiations.

It is expected that the frames, with overturned doors, can be provided with automatic openings activated on the basis of the ratio between the internal and the external temperature value; the opening at night favors the activation of a chimney effect which is able to guarantee a natural cooling of the Room and at a certain degree also of the adjacent spaces in summer months. On the southern and northern side external the positioning of brise soleils has been planned provided with anti-intrusion grids whose design recalls in the shape the present external window shutters.

An energetic analysis has been carried out referring to the current status and to the state of project.

Follow the features of the window frames and of the glass type in the current status and the three project hypothesis.

- **Roof refurbishment**

Among the energetic retrofit interventions analyzed in relation to the present case study, the substitution of the existing roof is a priority.

Currently there are abundant rainwater infiltrations through the roof, leading to the decay of the walls underneath, detachment of the frescos at the intrados of the ceiling, emerging of moulds in the lateral decorated walls; the intervention of extraordinary maintenance is therefore necessary.

The adoption of a ventilated roof system for the refurbishment of the roof permits to increase the energetic performances of the Room both in winter and summer time.

By choosing to adopt a proper thickness of transpiring insulation and a properly dimensioned ventilation chamber, the ventilated roof permits to insulate from the cold the space underneath in the winter period (lowering of the value of thermal transmittance) and to obtain also a good performance in the summer period (control of the values of periodic transmittance and displacing of the thermal wave); it favors the condensation dispersal thanks to the internal air stream, guarantees a longer duration of the used materials and effectiveness of the applied insulation. The studied insulating materials, apt to this kind of use, are two:

- The glass wool, a natural product which shows good insulating and physical properties. The glass wool is fire resistant, chemically neutral, non absorbing, light, flexible, simple to be worked and resistant to aging. Because of its features of moisture vapor transmission rate, thermal and acoustic insulation, mechanical resistance to compression and optimal reaction to fire, the glass wool is proper for the application in ventilated roofs. In the examined case, the use of a panel in mineral insulation “BAC CF N Roofine G3” with an 8 cm thickness and a density of 30 kg/m^3 , laid down between two layers of 1,9 cm thick OSB panels with

the function of increasing the volume of the roof and therefore improve its acoustic insulation and the performance in summer time. The overall thickness of this insulating packet is , therefore, of 11,8 cm.

- The wood fiber, material of plant origin produced from the manufacturing of conifer tree wood (spruce, larch, pines) derived from wastes and remains of saw mills and woods keeping, from which panels of different thicknesses, formats and densities are made.

The wood fiber is apt to applications of this kind because, thanks to its structure with open pores, it permits an excellent transpiration and the passing of vapor, is an hygroscopic material (able to regulate humidity) and, thanks to the high density, permits a very high thermal wave displacement (and therefore the protection of the internal spaces for summer heat).

The analyzed version of ventilated roof entails the exploitation of a double layer of insulating panels in wood fiber “Pavatherm”, with juxtaposed joints with a 4 cm displacement for each one and with a density (volume mass) corresponding to only 140 kg/m³, on which another layer of wood fiber “Natur isolant” only 1,9 cm thick of higher density (220 kg/m³) is laid down, whose aim is to distribute in the best way on the panel the weight of the upper roof (important precaution due to the panel rigidity. In this case the overall thickness of the insulating pack corresponds to 9,9 cm.

The thickness of the analyzed insulations has been determined trying to respond to two necessities:

- To obtain low thermal transmittances;
- To respect the constraint (RUE of the Bologna Municipality, art. N. 57 IS 1.1) of heighten the roof top of 20 cm maximum;

In the following lines are reported the features of the two current status and project hypothesis.

Analyzing the value of the pack thermal transmittance, takes place the passage from a value of 1,960 W/m²K of the current status to a value of 0,398 W/m²K corresponding to the same ventilated roof but using wood fiber.

The performance in summertime has been evaluated analyzing the values of periodic transmittance, attenuation and thermal wave displacement factor determined through the use of a simulation software in almost stationary conditions (Edilclima). The value of periodic thermal transmittance, i.e. passes from a value of 2,251 W/m²K of the current status to a value of 0,307 W/m²K in the state of project using glass wool and of 0,326 W/m²K using wood fiber. The highest thermal wave displacement is obtained using wood fiber insulation thanks to which from a value of – 1,397 W/m²K of the current status we pass to a value of -4,775 W/m²K in the state of project.

In both the analyzed project solutions the values of thermal transmittance can be further improved using a thicker insulation , always considering that two of the main constraints of the project are represented by the limitation of the weights that insist on the covering structures and by the respect of the constraint of roof top heightening of 20 cm maximum.

The thickness of the insulation therefore will be determined when the knowledge frame of the present structures will be in the conditions to be completed.

- **External walls insulation**

The East and South facing vertical enclosures directly bordering the exterior are at present covered with a layer of strongly deteriorated plaster; it is made of a mixture of a concrete base of the 30s, therefore with non philological procedures that would instead entail a lime based mixture.

Two intervention hypothesis have been considered, both implying the substitution of the functional layer, in the first case with a thermo-insulating plaster and in the second with a traditional lime-based plaster. Both solutions allow the control of the present thermal fields connected to the presence of deteriorated infra bricks cement layers.

The use of a lime made plaster in substitution of the present one is for sure the most respectful solution in relation to the characters of the walls on which the intervention is carried out.

The use of a thermo - insulating plaster guarantees

The use of a thermo-insulating plaster guarantees an improvement of the indoor comfort conditions both in winter time and in summer time thanks to the function that it can perform in insulating the walls from the exterior; the thermo-insulating plaster allows the transpiration through the wall avoiding the formation of moulds.

In the examined case the choice focused on the use of the thermo-insulating plaster named “Diathonite Evolution”, an already mixed thermo-plaster fiber reinforced with cork (grain size 0-3 mm), lime, diatomic powders and hydraulic binding agent.

It is a completely natural compost, ideal for contexts where eco-sustainable material are needed, ready to use, therefore it can be applied in a fast and efficient way on existing walls.

With the laying of only three centimeters of plaster the thermal transmittance value is halved, passing from being 1,633 W/m²K in the current status to 0,788 W/m²K in the state of project. The planned thickness could be even increased as a consequence of the positive resolution of the negotiation procedure that is being carried on with the Bologna Architectural and Landscape Heritage Preservation Authority . In the following part are reported the features of the constructive pack both in the current status and in the state of project (concrete plaster substitution with thermo insulating or lime plaster).

2.3.5 Project energy simulations for achieving the most efficient solution for conservation

After individuating and evaluating singularly the punctual interventions for the energetic retrofit of the case in exam, an Effectiveness Analysis at system level has been carried out, using the energetic simulation software at a dynamic regime Design Builder (with Energy Plus motor); the analysis has been divided in three phases through which it has been possible to determine the most performing combination of the windows and window frames solutions in relation to the priority to protect the frescos from the direct radiation of solar rays (tearing down UV radiations and protection from the infrareds) and in relation to the need to obtain an improvement of the internal comfort of the Room, not directly served by air-conditioning equipment, during summer and winter time.

Follows the description of the three phases of the Effectiveness Analysis.

- **Individuation of the glass type that best protects the frescos from direct solar radiation (1st step)**

By using the Design Builder Software four simulations of the entire environmental system have been done:

- Current status, with pine wooden window frames and clear glass 2 mm thick;
- HP Project a) substitution with new wooden/aluminum frames with $U_f=1,372$ W/m²K (in laminar pine with the internal surface varnished in dark brown color and the external in aluminum varnished in dark brown color) and triple insulating glass 3 + 3be/12 gas argon/4/12 gas argon/3+3be ($U_g=0,7$ W/m²K and $g=33$), highly performing in winter time.
- HP Project b) substitution with new wooden/aluminum frames $U_f=1,372$ W/m²K (laminar pine with the internal surface varnished in dark brown color and the external in aluminum varnished in dark brown color) and double insulating glass layered 5+5be/16argon/4+4 ($U_g=1$ W/m²K and $g=27$);
- HP Project c) substitution with new wooden/aluminum frames $U_f=1,372$ W/m²K (laminar pine with the internal surface varnished in dark brown color and the external in aluminum varnished in dark brown color) and double insulating glass layered 4+4be16argon/4+4 ($U_g=1$ W/m²K and $g=27$), highly performing in summer time.

The results achieved from the analysis of the three project hypothesis compared to the current status highlight that, in relation to the priority target of protecting the frescos from the UV radiations and the infrared rays the best performance is obtained through the positioning of glasses that do have the characteristics individuated in hypothesis HP c.

In front of a performance that is for the remaining aspects quite similar to the one guaranteed by the other two solutions, this glass choice permits a noticeable limitation of the solar gains in summer time, going from 1658,80 kWh of the current status to 282,12 kWh of the project hypothesis.

A further convenience of the HP c if compared to the HP a hypothesis is due to the fact that the chosen triple glass in this one, being heavier, presents higher criticalities and consuming in the motioning in time and has a much higher cost.

In the beginning, was considered the application of the same glass for all the windows. Successively, was contemplated the use of glass with a lesser thickness for windows facing the attic (north and west); a window

frame leaning out towards the interior, in fact, doesn't have to provide solar control but must only be low emissive; for these windows was analyzed the hypothesis of a low-emissive but not selective glass.

From the analysis done it is tested that in the two cases (selective glass on 10 window frames, selective glass for east-west facades and only insulating low-emissive glass for north-south facades) the performances reached are quite similar in summer and winter time; the main differing aspect happens in the dispersions through the windows in winter time that result to be higher in comparison to the dispersions obtained using only one typology of window frame offering a lower performance (due to the higher transpiration of the window frames towards the interior) with the same values of the other components, among which the internal temperature. In summer, instead, the combined solution of the two window frames performs in a better way avoiding the injection of further heat in the environment.

So, if the solution designed for HP c is applied only on the window frames leaning out towards the exterior using lighter glass types in the windows facing the attic, it improves even more its performance in terms of "optimal levels in function of the costs", as the EPBD2 suggests.

- **Definition of the pack of interventions on the roof that permits an improvement of the energetic and internal comfort conditions of the room (2nd step)**

After defining the most effective window solution (frame and glass), five intervention hypothesis have been analyzed using the Design Builder Software, obtained combining the technological solutions studied in the previous chapter.

Follow the five hypothesis analyzed at system scale (in bold the technological solution that differs from the one of the previous hypothesis):

HP1	High efficiency window frames (selected in phase 1)
	Ventilated and insulated roof with glass wool + a double layer of panels oriented fibers (OSB)
	Insulation of the roof from its extrados with glass wool
	Remake of the external façade plaster using traditional lime plaster

HP2	High efficiency window frames (selected in phase 1)
	Ventilated and insulated roof with wood fiber
	Insulation of the roof from its extrados with glass wool
	Remake of the external façade plaster using traditional lime plaster.

HP3	High efficiency window frames (selected in phase 1)
	Ventilated and insulated roof with wood fiber
	Remake of the external façade plaster using traditional lime plaster.

HP4	High efficiency window frames (selected in phase 1)
	Ventilated and insulated roof with glass wool + double layer of panels with oriented fibers (OSB)
	Remake of the external façade plaster using traditional lime plaster.

HP5	High efficiency window frames (selected in phase 1)
	Remake of the external façade plaster using traditional lime plaster.
	Insulation of the roof from its extrados with glass wool

On the basis of the energetic analysis conducted on a dynamic field, the HP3 and HP4 intervention hypothesis, very similar to each other, result to be the most succeeding and satisfying. Between the two we consider to be more suitable for the case in exam the HP3 which uses the wood fiber as roof insulating material and doesn't need further OSB layers to increase its thermal mass. Therefore it results to be faster and easier to be laid down together with a more limited weight (47 kg/m² of the ventilated roof with wood fiber against the 63 Kg/m² of the ventilated roof with glass wool); the wood fiber reveals to be efficient most of all in summer thanks to a volume mass that permits a significant displacement of the thermal wave (the periodic thermal transmission goes from a value of 2,251 W/m²K of the current status to a value of 0,326 W/m²K) besides good acoustic properties; it is an hygroscopic material, useful feature in environments that are sensitive to humidity, and is ideal for contexts where eco-sustainable material are needed.

From the diagram comparison between the curve evolution of the superficial exterior and interior temperature of the covering roof in the current status and in the project at the 17th of July (see following diagrams) is highlighted in fact that the daily displacement increases in the project hypothesis.

Across the whole year the intervention solution valuable as the most effective turns out to be the following:

HP3	window frames with wooden/aluminum window frames (in laminar pine with the internal surface varnished in dark brown color and the external in aluminum varnished in dark brown color), with $U_f=1,372$ W/m ² K and double insulating glass 4 + 4be/16 gas argon/4+4 with $U_g=1$ W/m ² K and $g=26$, total reduction of UV radiation ($U_w=1,3$ W/m ² K as defined by the prospect c.3 of the norm UNI/TS 11300-1)
	Ventilated Insulated roof with wood fiber
	Remaking of the plaster of the external façade with plaster based on traditional lime

- **Test of the performance of the walls consequent to the plaster substitution (3rd step)**

Once individuated the HP3 as the most efficient intervention hypothesis, it has been tested, as last analysis, the way in which the performance of the structure changes locating on the external facades, in the place of a traditional lime based plaster, an already mixed thermo-plaster fiber reinforced with cork (grain size 0-3 mm), lime, diatomic powders and hydraulic binding agent

From the analysis of the obtained data through the energetic simulations done in the winter and summer period, it has been evidenced a slight improvement in the performance of the external walls consequent to the thermo-plaster insulation.

In the winter period, in fact, the heat dispersions reduce themselves going from a value of -1664,39 kWh per year to a value of -1232,43 kWh per year; in the summer period, instead, the external walls increase their collaboration with the structure in expelling the heat from the interior going from a gain of -73,16 kWh per year to a value of -255,16 kWh per year.

It is proper to point out that, even if the solution with thermo-plaster produces in wintertime improvements in terms of heat dispersion through the walls of -431,96 kWh per year and in summer time improvements in terms of heat expulsion of 182,00 kWh per year, these values do not bring a significant improvement in the overall performance of the "Sala urbana", able to justify this project choice, especially if we consider the realization costs of a thermo-insulating plaster (the "optimal level referred to the costs" suggested by norm EPBD" is not achieved); besides this, given the traditional lime – made plaster higher compatibility with the historical walls compared to a cork-made thermo-plaster, the making of a traditional lime-made plaster for the exterior is considered to be more proper.

3 Project of the interventions and formal approval by the Heritage Preservation Authority

3.1 Guidelines for interventions (Municipal collections)

The actions to be taken within the Municipal Collections are orientated primarily to the execution of works relating to the room M 2F 17S called Sala Urbana or Sala degli Stemmi. The interventions to be implemented are urgent because the state of deterioration is very advanced. Work will focus primarily on the replacement of the roof with waterproofing and replacement of existing windows. In the realization of these maintenance operations, we introduce the aspect of energy saving, which normally would not be introduced on historic buildings and protected by the Superintendent. Design objective involves the application of the legal limits that prevent energy loss to building components and building envelope.

3.1.1 Roof refurbishment

From the investigations conducted it was decided to schedule an urgent replacement of the roofs of the hall and to provide a conservative restoration of the frescoes on the ceiling through the consolidation to be carried out in extrados. The limit values of reference for the covers as by D. Decree 311/2006 for Zone E are equal to a 0, 30 W/m² K. For these reasons it is assumed to isolate the cover through the use of insulating material made of wood fiber breathable, which must be applied on the extrados of the floor covering of the attic. In addition to the insulator, this material performs a protective function against the structure, especially when this is made of wood.

The roof must be completely replaced and it will be enough to realize a ventilated roof, because normally the insulation is introduced in the last opaque element facing the outside. To get the best benefits one could introduce an insulating layer (but taking into account the loads allowed by the structure). In this case it is necessary to use a transpirant insulating material suitable for summer periods, which has a low thermal diffusivity (thermal conductivity / density x specific heat, such as insulating materials based on wood fiber). With this arrangement is obtained, therefore, a low thermal transmittance periodic Y_{ie} , value that indicates the transmittance during the day, which should be $no > 0.20 \text{ W/m}^2\text{K}$.

The best insulating materials with these characteristics are those in wood fiber, the maximum thermal conductivity should be around 0.043 to $\lambda \text{ [W / (mK)]}$. For the isolation of the floor, the minimum thickness of the insulation will have to be of 8 cm, assisted by the panel of wood fiber, cloth transpirant waterproof, air chamber that allows for ventilation, and a wooden partition as a finish.

The base of the floor, with the introduction of insulating materials could achieve performance that is below the transmittance $U = <K \text{ 30W/m}^2$. Here below a schematic diagram of the materials that could be used for the last base of the attic.

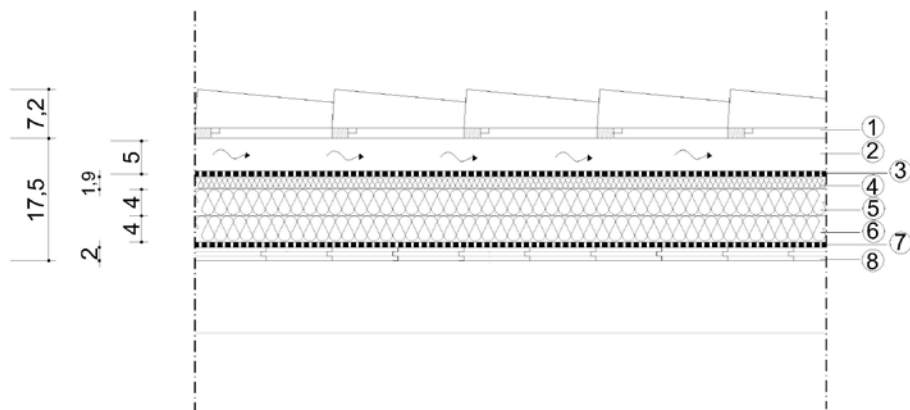
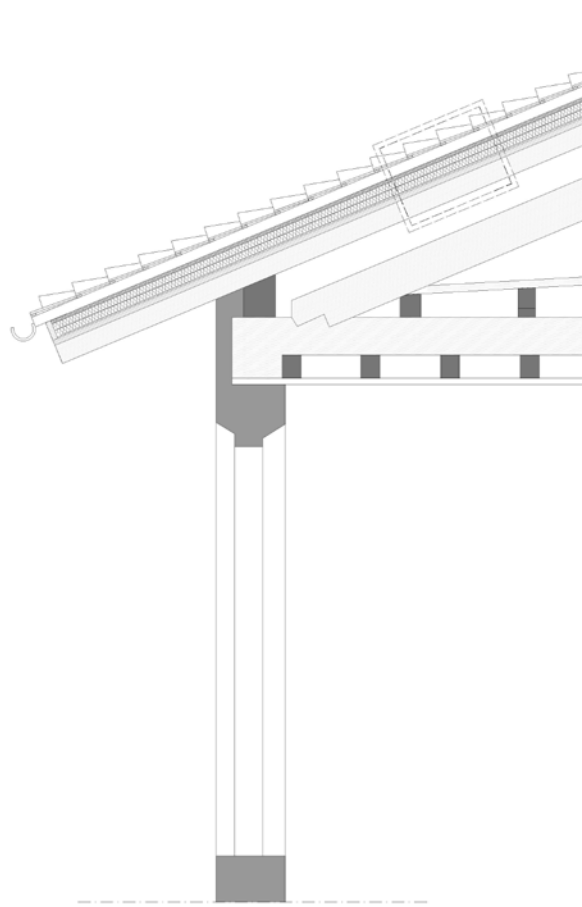

- ① Copertura in tegole di argilla
- ② Intercapedine d'aria s. 50 mm
- ③ Telo impermeabilizzante sottotegola s. 0.4 mm
- ④ Pannelli in fibra di legno (densità 220 kg/m³) s. 19 mm
- ⑤ Pannelli in fibra di legno (densità 140 kg/m³) s. 40 mm
- ⑥ Pannelli in fibra di legno (densità 140 kg/m³) s. 40 mm
- ⑦ Barriera all'aria e freno al vapore a diffusione igrovariabile s. 0.2 mm
- ⑧ Assito in Legno di pino flusso perpendicolare alle fibre s. 20 mm

Schematic stratigraphy of insulating

3.1.2 Windows substitution

In case of replacement of windows in Zone E, the limit established by law is 2.2 W/m²K.

This value provides a better performance of glazed openings, without exceeding its performance that should be at the expense of comfort especially as regards the contribution of the windows facing south which would produce excessive heat in summer creating a greenhouse effect, even for windows oriented to the west and east, is suspected to be observed the same criterion. As for windows oriented to the north you can use a window with improved performance. It's necessary to use selective glass to reflect and protect the frescoes from the sun, but at the same time retaining heat in the winter period.



For windows facing south which have a double frame, it is proposed to replace them with a single frame that maintains the same design. It can be positioned flush with external does not change the design on the façade (keep in mind that at present lacks counter the window) with the application of a drip for rain swing. Given the limits imposed by the design of the window (which does not allow the use of significant thickness of the profiles) and the possible limitations that may be encountered in fixation to the wall (but heavy-performance windows can be anchored to masonry / plaster deteriorated), it is suggested to obtain the same performance limits of the frame by pushing further the performance of the glass instead of the profiles, but with particular attention to the seals and the thermal break.

For windows facing east and west: it is proposed to replacing the windows while keeping the existing design, leading to a total transmittance of the window equal to $U_w = 2.2 \text{ W/m}^2\text{K}$ (with reduced thickness of the frame, which could be around to 70 mm). To get this performance should be the window with double glazing and cavity (16 mm) the introduction of gas (type: Argon), to increase performance.

The glass must be selective (in the winter periods and retain the heat in the summer periods reflect it) in such a way as to avoid the UV rays which produce the bleaching effect of the frescoes, thus limiting the solar gain and bright.

For windows oriented to the north: it is recommended to replace the frames, which while maintaining the current design will lead to overall transmission of the frame of $U_w = 1.9 \text{ W/m}^2\text{K}$. The glass also in this case will have to be selective.

Given the nature of the historic building, the type of window should be wood and built by artisans, but to address the maintenance issue, you could opt for a mixed window, which presents to the outside of an aluminium frame with thermal break, treated with brown colour and towards interior a wood frame.

Any option you choose, and be accepted by the superintendent, it is essential that the frame can be opened in order to create natural ventilation in summer months (although obscured by curtains specially arrears). May be developed further (with the manufacturers) the possibility of tilting windows (flap) with opening inwards and downwards, in such a way as to allow the flow of air in a direct way (chimney effect).

The window must be equipped with an automated system for its opening. Such a system must have a sophisticated automation that can be adjusted according to temperature and moisture present in the room, and will also provide for the automated closure in case of rain.

For windows facing south will be introduced an automated system that detects light output and regulating their opening and closing.

The adjustment takes place through an external sensor and heated internally connected to the controller. The control unit, mounted in modular container, allows the adjustment of the delay times on the drive output, on disconnection of the output and the sensitivity adjustment of outside sensor.

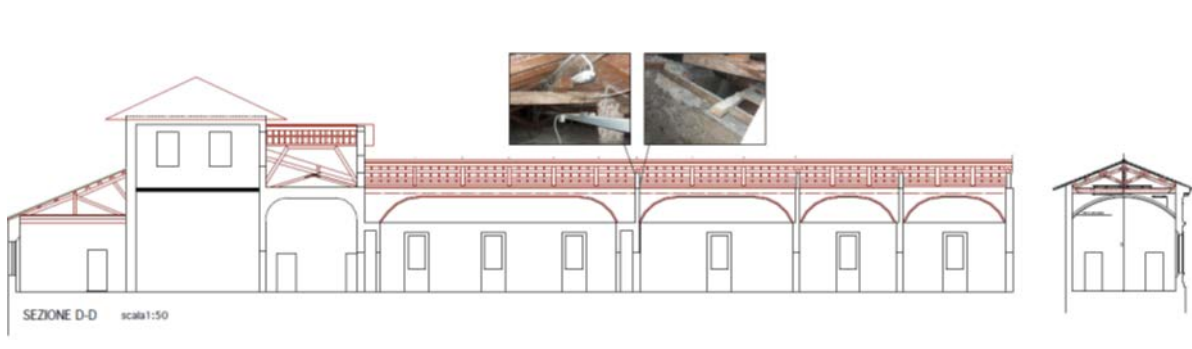
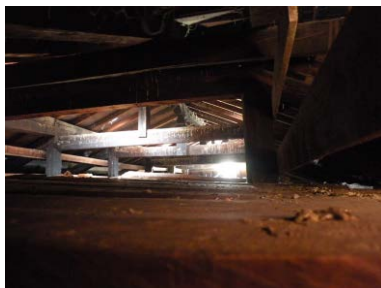

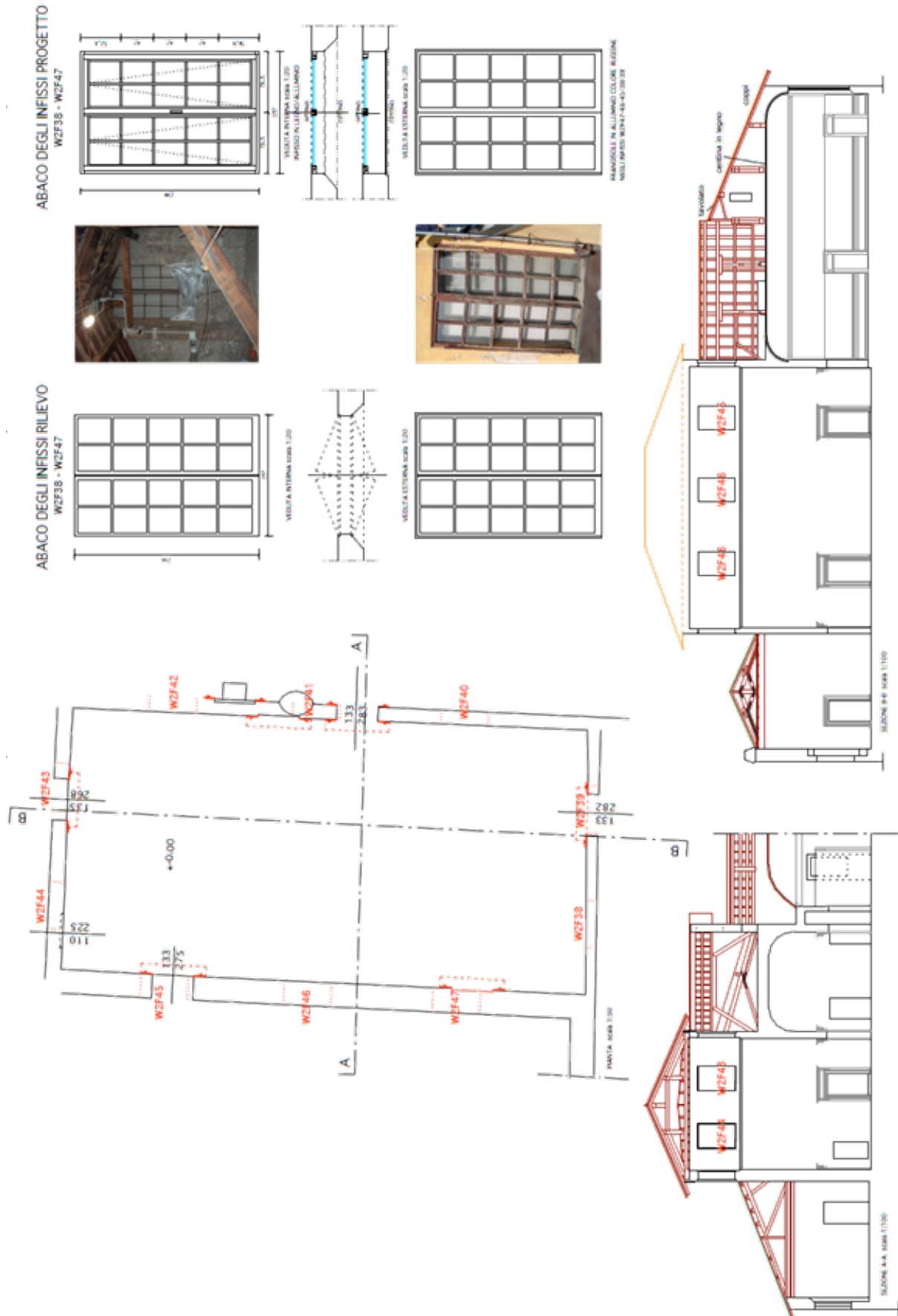

3.1.3 Domotics equipment installation

The project of substitution of the present window frames, their inaccessibility caused by their height from ground level and the information collected during the monitoring of the indoor microclimate conditions in particular in summertime have contributed to the decision of installing in the “Urban” room a microclimate general control system able to activate the automatic opening of the transom windows with the aim of generating a natural ventilation following specifically conceived performance scenarios. Therefore the installation of a domotic equipment was planned (Bus) with Konnex technology in order to coordinate all the automatic devices in the field.

The target is to achieve a flexible and expandable tool that can lead to support the development of a new strategy of preservation of the cultural heritage, still in progress, able to exploit all the technological opportunities that will emerge during the project.

Solutions that contemplate the automatic opening of windows in summer time have been simulated and tested in the project for cases in which the interior temperature doesn't exceed of 3 grades the exterior (natural cooling).

The performance of the windows shutters automatic opening scenarios will therefore be directly conditioned by the values of the environmental parameters like temperature and humidity, both internally and externally to the room, by the air speed survey and by an external meteorological station in order to have all the necessary data in order to evaluate the differences among internal and external air temperatures, in particular in order to highlight the rain and wind speed conditions that determine the shutters non-opening or closure.

The planned system will therefore be able to:

1. determine the condition of the window, intended as open or close window;
2. permit the regulation of the opening grade of the window, calculating the opening percentage of the window shutter;
3. permit the manual unlock of the windows preventing the automatic functioning;
4. be provided with a proper number of temperature and humidity probes, for different heights, in order to measure the internal climate conditions of the room;
5. be programmed with specific scenarios activation boundary-levels at the specified temperature and pressure conditions.
6. be provided with a meteorological station located outside the room;

It is necessary to plan a simultaneous automatic movement of the curtains positioned on the windows to be moved in order not to let them be an obstacle to the opening and closing operations of the window shutters. We specify that the curtains type will have to be kept with horizontal opening.

The proposal of installing in this room a system provided with these characters is derived from the necessity of keeping a microclimate for the preservation of the walls paintings layers that would have for sure been altered in the hypothesis of substituting the existing shutters and window frames, with highly efficient ones for what is concerned with energy consume, without being able on the other side to intervene with natural air turnover and with mechanical controlled ventilation that would have been much more impacting considering the presence on every wall of frescoes and decorations.

3.1.4 New led-lighting devices

The energetic diagnosis highlighted that a very high amount of electric energy, corresponding to the 25,33% of the entire energetic consume of the Museum area is consumed for light sources.

Inside the “Urban” room, project surveys of the natural illumination levels have been carried out together with project partners ARUP and Bartenbach, Lichtlabor and the possibility of providing the “Sala Urbana with led light sources and in a future perspective with solutions able to significantly reduce the electric consuming due to lighting, i.e. working with power regulation with respect to the effective visitors present in the room, have been studied.

The project has planned the integration of the new light led sources with the domotic equipment installed inside the room in order to program differenced use scenarios following different exposition solutions and different ignition/shut down situations with respect to the presence in the room of eventual visitors. In this case is quite evident the concept of exploiting all the meteorological and environmental lightness data for regulating the lighting devices emissions in order to obtain the highest energy saving while guaranteeing the best lighting conditions.

3.1.5 Authorization to proceed with the realization of works

ITALIAN MINISTRY OF CULTURAL HERITAGE
AND ACTIVITIES
*Supervision for architectural treasures and landscape
for the provinces of Bologna, Modena and Reggio Emilia
Via IV Novembre 5, 40123 Bologna
Telephone number: +39 0516451311 Fax number: +39 0516451380*

To the Municipality of Bologna
Department of Public Works
Operating Unit of public historic buildings
For the kind attention of Architect Manuela Faustini Fustini
Piazza Liber Paradisus 10
Torre B
40129 Bologna

Prot. No:11147

Class:34.19.07/164

Annexes: 6

**Answer to the protocol 187 of 29/02/2012
(our protocol No. 3090 of 29/02/2012)**

**and to the protocol 553 of 21/06/ 2012
(our protocol no. 9838 of 21/06/ 2012)**

SUBJECT: Municipality of Bologna- Building located in Piazza Maggiore and known as Palazzo d'Accursio. (Relevant with the Legislative Decree 42/2004 and subsequent modifications and additions- "Code of cultural and environmental heritage", pursuant to the article 128, with the document of 31/12/1911 issued as ex lege 364/1909).

Owner and applicant: the Municipality of Bologna

Work of: extraordinary maintenance of the Sala Urbana (Urban Hall), (Roofing and replacement of windows)

Authorization pursuant to the article 21 prg.4 of the Legislative Decree 42/2004 and subsequent modifications and additions

With reference to the aforementioned, having analyzed all the technical documentation sent with the marginal notes and given the latest clarifications, considering the special historical and artistic characteristics of the present hall,

having acknowledged that the work is about the replacement of the damaged wooden window and the maintenance of the roofing and the false ceiling,

having assessed all the methods and solutions aimed at guaranteeing a perfect insulation from rain water seepage and a suitable microclimate inside the hall,

this Department authorizes, as far as it is concerned, the work which is deemed to be necessary to preserve and protect the building, and the following conditions must be followed:

- -First, great attention to the scaffoldings and the temporary works of the hall must be paid and the best measures for the protection of the hall must be taken;
- -In order to tailor all the suggested interventions, once the scaffoldings will be put up, the roofing will be inspected to control the preservation status of its components and verify any further work to improve the anti-seismic design of the building. For this purpose, an accurate geometrical survey with photos and with any detailed documentation will be done and then analyzed by this office;

- Regarding the new windows (made of wood/aluminum, and component brise soleil etc.), subject to prior analysis of suitable samples, we reserve the right to verify and agree upon the formal and chromatic characteristics together with any further detail during the construction;
- It is compulsory to send this Department a written document with the date of the beginning of the work at least 10 days in advance and to specify the name of the technician responsible for the work.

Waiting for the above mentioned documentation, which could be analyzed in greater detail once the work has started, we are giving back the copy of the received documentation with the approval stamp which is subject to the above mentioned provisions.

The Responsible for the procedure: Architect Franca Iole Pietrafitta

FIP/sta

THE SUPERVISOR
(Architect Paola Grifoni)

2.3 CS3 Palazzina della Viola Bologna (Italy)

2.3.1 LCS-Team

LCS-Team was constituted by 3encult partners, the stakeholder and conservation experts:

UNIBO's 3ENCULT partner team (P13):

- Luca Benini
- Camilla Colla
- Elena Gabrielli
- Marco Giuliani
- Giacomo Paci
- Francesco Ubertini

Restorers

- Ada Foschini-
- Alessandra Freo

AUTC (Technical Office of the University)

- Roberto Battistini
- Andrea Braschi
- Dina Uccelli
- Anna Vecchi

Superintendent Authority for Cultural Heritage

- Franca Iole Pietrafitta

2.3.2 Building measures and conservation compatible efficiency solutions

Palazzina della Viola is owned by the University of Bologna and presently used as University department (International Relations Department). After a few years of abandon, the renovation works in the building started almost at the same time as the 3ENCULT project's start, although the intervention project had been designed a few years earlier by the technical office of the university (AUTC).

During project proposal preparation and negotiation and at the beginning of the project, contacts were taken with the Technical Office of the University and information exchanged. During the approx. 18-month duration of the building site, a number of meetings were requested by the 3ENCULT UNIBO's team (DICAM + DEI Department) to the AUTC and in particular to the Architect acting as Director of Work, and to the Surveyor acting as second-in-place. During these meetings, repeated experiences showed that there was interest by AUTC in being informed about the planned project activities in the Case Study but little information was provided to UNIBO's Team by AUTC about the design, the time progression of works and the specific activities on-site with a little advance time. Also, repeated conversations showed that there was no possibility that the site works of intervention design could be modified according to the 3ENCULT suggestions, because of budget constraints. Good exchange of information and collaboration was achieved by UNIBO's team on site with the restorers carrying out cleaning, protection and restoration of the delicate artifacts present in the building, in particular of detached frescoes hanging on walls and painted timber-beam ceilings.

Several experimental diagnostic studies and investigations were conducted on site by UNIBO's Team and as well as a WSN monitoring system was installed in the CS during the building site works and afterward the refurbishment.

2.4 CS4 The Material Court of the Fortress, Copenhagen (Denmark)

Fæstningens Materialegård,

2.4.1 LCS-Team

KA (P02)

Building owner:

Realdania Byg: Nørregade 29, 5000 Odense C, tlf.: +45 70 11 06 06, mail: info@re.dk, web: www.realea.dk

The Heritage Agency of Denmark, a body under the Danish Ministry of Culture:

H.C. Andersens Boulevard 2, 1553 København V, tlf.: +45 33 74 51 00, mail: post@kulturarv.dk, web: www.kulturarv.dk

Architect:

Varmings Tegnestue ApS: Kronprinsessegade 8, 1306 København K, tlf.: +45 3311 2213, fax.: +45 3311 8184,

mail.: mail@varmings-tegnestue.dk

Engineer concerning constructions:

Jørgen Nielsen Rådgivende Ingeniører A/S: Lille Kongensgade 34, 1074 København K, tlf.: +45 3311 8850, fax.: +45 3314 3301, mail.: ing@jorgen-nielsen.dk

Engineer concerning energy consumption:

Strunge Jensen A/S: Rådgivende Ingeniører, Solrød Center 29, 2.sal, Postboks 111, 2680 Solrød Strand, tlf. +45 5614 1030,

fax.: +45 5614 5230, mail.: ingenior@strunge.dk

2.4.2 Efficiency solutions and Heritage Authority comments

Preservation issue surveillance -

CS4 [The Material Court of the Fortress](#)

Original constructed in 1768, the building is now eighteen bays long and two stories high, with high roof pitch on which four chimneys and a firewall is placed. On the roof there are thirteen dormers facing towards the courtyard, and eleven to the street.

The building was initially used for material storage, but conversions started shortly after the building was built. In 1803 the building changes with office and housing functions at the expense of the material storage. The building has been the frame for various functions such as storage, residences, archives, and offices. The expansion marks are still evident today

The original static scheme of the building, a longitudinal beam in the center was relatively early replaced with a masonry wall. This replaced the open illuminated space by smaller rooms with one-sided daylight intake.

The building complex has both qualities as structural space and valuable details from several periods. Structural differences are noted as quality. Thus there are both reasonably intact and consistent room structures with remaining ceiling stucco and panels, doors from a period corresponding to the room structure.

The main heritage values are:

- The existing windows
- Ceiling stucco and panels
- The structural space and the plan disposition
- The courtyard

Below is the optional energy interventions listed in seven groups (Windows and sun screening, Insulation and building tightness, Ventilation, Heat and cooling installations, Electricity, Solar panels and Users). For each

suggested intervention is noted comments and point of view from the **Danish Agency for Culture and the architects**.

Proposed interventions in *italic* were not accepted.

Windows and sun screening

(1) New windows. Energy low windows with "Fake-bars". Minimizing heat loss. Sun protection glass. Minimization of thermal bridges.

Authority (Danish Agency for Culture):

The windows in the building 4 is original/old, and are an important part of the conservation values. Basically old windows should be restored rather than replaced, only if they are in a very bad condition, a new window can be accepted. Then the new windows should be produced like an copy of the old, with single glass and rebates.

(2) New energy glass in inner window frames. The glass is replaced with coated energy glass.

Authority:

Can be done if joinery details and glass colour can be accepted.

(3) Internal sun blinds.

Authority:

Sun protection, built into a historic window cannot be accepted.

According to the "Building Conservation Law" (Bygningsfredningsloven) Danish Agency for Culture have no authority to refuse loose fixtures, as curtains and blinds.

(4) Exterior shading. Sunblinds or other external possibilities of shading.

Authority:

New shutters or awnings are generally not acceptable as it will greatly change the façade character which is part of the important preservation values.

Insulation and building tightness

(5) Interior insulation of walls. Interior insulation to existing outer walls.

Authority:

It is generally not acceptable to move the panels and mountings in the historical material. In some cases it is acceptable to make an insulating inner wall if there are no panels or other architectural details and only in secondary rooms.

The Architect (Varmings Tegnesteue):

If the insulation of the building has a great energy impact, it can be accepted, a partly insulation could be a solution.

(6) Exterior insulation of walls.

Authority:

Outside additional insulation cannot be accepted because it will change the facade character, a part of the buildings main heritage value.

(7) Insulation of "slanted ceilings". Increasing the insulation thickness.

Authority:

An interior insulation in the "appropriate" dimension of eaves void and slanted ceilings can be accepted.

(8) Insulation of slab. Increasing the insulation thickness.

Authority:

The Archaeological Museum (Det arkæologiske museum) must be informed by work done in the ground, and supervision is needed if there is building archaeological traces.

The Architect:

There are many partitions to be stabilized. Furthermore exposed frames and secondary carpentry must be stabilised during implementation.

(9) Using new insulation types, "super thin". Thin insulation added to the sides of existing dormers.

Authority:

If the insulation can be fitted to existing windows and walls it can be accepted.

The architect:

The Insulation type requires air in front, and thereby increase the overall construction thickness. Furthermore, the effect is uncertain.

(10) Establishment of the building tightness. Building envelope is examined for leaks.

Authority:

If the tightness is carried out with the traditional materials and traditional craftsmanship it can be acceptable.

Ventilation

(11) Ventilation, natural. Ventilation through windows.

Authority:

Window is designed with the intention to be opened. Use of the window is accepted.

Constructing engineer (Jørgen Nielsen):

Ventilation of spaces through the windows can be used in single office rooms. In large office space there must be mechanical ventilation.

(12) Ventilation, hybrid. Ventilation of space with fresh air intake in the building envelope and exhaust air above the roof.

Authority:

Exhaust air through the chimney can be accepted.

Standard fresh air intake in the windows cannot be accepted.

The architect:

Suspended ceilings in rooms where there are stucco is not acceptable.

In bathrooms suspended ceiling is accepted.

(15) Fresh air intake via solar walls, active glazing. In relation to section 12, the possibility to heat the fresh air through solar walls, or active glass panels is investigated.

Authority:

The collector will be a significant change on the listed building façade, that is a part of the buildings main heritage value, so it cannot be accepted.

The architect:

Exterior of the building forms a whole, which should be preserved. A solar wall is different in materiality than rest of the building.

Heating and cooling

(16) Cooling the rooms via recirculation of air in the rooms. Replacing the radiators with fancoils. Recirculates the air, and gives the possibility to operate each room individually .

Authority:

Basically, it is unacceptable to build fixed mechanical device in a historic building.

Compared to a conventional radiator this is slightly wider and must have a two sets of tubes, also for the cold pipes. The appearance of the device have to be adapted to the house in the best possible way.

The architect:

The architectural impact is very small compared to all other ventilation systems.

(17) Cooling of rooms through passive cooling. Cooling is established by cooling of ceilings or walls.

Authority:

If the intervention is done without major destructive action with and through existing walls or new walls is can be acceptable.

New ceilings will have a significant impact on the individual rooms, it will hide details and surfaces.

The architect:

The ceilings in building 4 is an essential part of the architecture. There cannot be created suspended ceilings in the building where windows goes all the way to the ceiling.

(18) Cooling, "heat pump air". Cooling with surplus heat is deposed to the air in an outdoor part.

Authority:

The intervention can't be assessed at the time. If the necessary documentation is obtained, it can be considered, if it doesn't disturb the buildings main heritage value.

(19) Cooling, "heat pump soil". Surplus heat is deposed in the soil through pipes.

Authority:

The intervention can't be assessed at the time. If the necessary documentation is obtained, it can be considered, if it doesn't disturb the buildings main heritage value.

The architect:

Under the condition that the protected area in the courtyard is respected.

(20) Cooling, "Heat pump ground/sea water". Cooling where surplus heat is deposed to sea or groundwater.

Authority:

The intervention can't be assessed at the time. If the necessary documentation is obtained, it can be considered, if it doesn't disturb the buildings main heritage value.

(21) Heating established through "traditional" radiator heating.

Authority:

The intervention can't be assessed at the time. If the necessary documentation is obtained, it can be considered, if it doesn't disturb the buildings main heritage value.

The architect:

Heating combined with a cooling system. This unit has roughly the same dimensions as the fancoil. Traditional radiator solution is therefore deselected.

(22) Heating established though underfloor heating systems.

Authority:

The intervention can't be assessed at the time. If the necessary documentation is obtained, it can be considered, if it doesn't disturb the buildings main heritage value.

(23) Water production, central. DHW will be established at a central location and distributed to the taps.

Authority:

The intervention can't be assessed at the time. If the necessary documentation is obtained, it can be considered, if it doesn't disturb the buildings main heritage value.

(24) Water production, decentralized. DHW will be established in smaller containers near the taps.

Authority:

The intervention can't be assessed at the time. If the necessary documentation is obtained, it can be considered, if it doesn't disturb the buildings main heritage value.

(28) Gathering of rainwater. Rainwater is gathered and used to flush toilets.

Authority:

The intervention can't be assessed at the time. If the necessary documentation is obtained, it can be considered, if it doesn't disturb the buildings main heritage value.

Electricity

(25) Energy-saving light sources. Use of alternative light sources for permanent lighting.

Authority:

The intervention can't be assessed at the time. If the necessary documentation is obtained, it can be considered, if it doesn't disturb the buildings main heritage value.

The architect:

If light quality and color is acceptable.

(26) Daylight control.

Authority:

The intervention can't be assessed at the time. If the necessary documentation is obtained, it can be considered, if it doesn't disturb the buildings main heritage value.

(27) Electricity supply for electric components are managed centrally.

Authority:

The intervention can't be assessed at the time. If the necessary documentation is obtained, it can be considered, if it doesn't disturb the buildings main heritage value.

Solar panels

(29) Solar panels for hot water production. Solar panels are connected to hot water production.

Authority:

The intervention can't be assessed at the time. If the necessary documentation is obtained, it can be considered, if it doesn't disturb the buildings main heritage value.

The architect:

Solar cells and solar panels on the roof surface is foreign to the roof materiality. The size of these elements are so large koncekvenser of the overall expression.

(30) Solar panels for heating. Collector are connected to heat production.

Authority:

The intervention can't be assessed at the time. If the necessary documentation is obtained, it can be considered, if it doesn't disturb the buildings main heritage value.

The architect:

Solar cells and solar panels on the roof surface is foreign to the roof materiality and affect the experience of roof as an architectural whole. The size of these elements will have consequences of the overall expression.

(31) Solar cells. Solar cells to produce for electricity.

Authority:

The intervention can't be assessed at the time. If the necessary documentation is obtained, it can be considered, if it doesn't disturb the buildings main heritage value.

Users

(32) Decentralized location of heat-emitting components. Move heat-emitting office devices from office spaces to a shared serverroom.

Authority:

The intervention can't be assessed at the time. If the necessary documentation is obtained, it can be considered, if it doesn't disturb the buildings main heritage value.

(33) Shared canteen. Shared facilities for kitchen and canteen.

Authority:

The intervention can't be assessed at the time. If the necessary documentation is obtained, it can be considered, if it doesn't disturb the buildings main heritage value.

The architect:

The architecture building 11 have can best cope with the visible pipe the ventilation require. Furthermore, this building is ideal for large spaces.

(34) Shared meeting and conference facilities.

Authority:

The intervention can't be assessed at the time. If the necessary documentation is obtained, it can be considered, if it doesn't disturb the buildings main heritage value.

The architect:

The architecture building 11 have can best cope with the visible pipe the ventilation require. Furthermore, this building is ideal for large spaces.

(35) Weather porch. Main Access fitted with airlocks.

Authority:

There cannot be established an outside porch in the house entrances, as this will be one significant intervention in relation to the façade that is a part of the important preservation values.

It is possible that it can be established inside the building. That will be evaluated on a specific project.

The architect:

You cannot make any actual airlock. Admission is both porch and stairway.

2.5 CS5 Secondary School NMS Hötting – Innsbruck (Austria)

2.5.1 LCS-Team

Case study leader/ 3ENCULT responsible partner:

Wiss. Leitung: Dr. Rainer Pfluger, UIBK (P04)

Architekt: Arch Dipl-Ing Gerald Gaigg

Jahnstr 13
6020 Innsbruck
Telefon +43 512 585832
Fax +43 512 585832

Gebäudeeigentümer und Bauherr:

IIG, Die Immobilien Gesellschaft der Stadt Innsbruck

Roßaugasse 4, 6020 Innsbruck

+43 (0) 512-4004-0, info@iig.at

Responsible monument conservation office:

Landeskonservatorat für Tirol

A-6020 Innsbruck, Burggraben 31

Tel.: +43-512-582 932, 582 087

Fax: +43-512-581 915

Email: tirol@bda.at

2.5.2 Denkmalbegründung

Die Innsbrucker Immobiliengesellschaft wurde mit Schreiben vom 8.7.2008 über die beabsichtigte Unterschutzstellung der Hauptschule Hötting am Fürstenweg 13 auf Gst. 1570/7 nach Paragraph 2a DMSG gemäß Verordnung „Innsbruck 1“ informiert. Mit Schreiben vom 27.1.2009 wurde die erfolgte Unterschutzstellung gemäß Verordnung mitgeteilt.

Dem Schreiben vom 8.7.2008 war nachfolgende Begründung beigelegt:

1929 - 1931 nach Entwurf von Franz Baumann und Theodor Prachensky errichteter Schulbau mit betont sachlicher, kubisch akzentuierter Außenerscheinung, Halle und Stiegenaufgang. Blumen-Fresko von Hilde Nöbel von 1952 im Untergeschoß. *Denkmalschutz nach §2*

Im Band 1 „Österreichische Architektur im 20. Jahrhundert“ von Friedrich Achleitner wird der Bau folgendermaßen beschrieben: S 366

In Innsbruck wurde in den zwanziger und dreißiger Jahren im Schulbau ein relativ hohes Niveau erreicht. Zu den interessantesten Beispielen gehört zweifellos die Höttinger Hauptschule, deren Planung ein Wettbewerb vorausging. Die Architektur des Baues steht unter dem Einfluß der Peter-Behrens Schule, die zu dieser Zeit in Österreich besonders dominierte. In der äußeren Erscheinung betont sachlich, kubisch akzentuiert, ist die Eingangspartie mit Halle und Stiegenaufgang besonders schön.

Im Buch „Franz Baumann Architekt der Moderne in Tirol“ von Horst Hambrusch, Joachim Moroder und Bettina Schlorhauser wird ausgeführt: S 188-195

Mit der Schulreform und der Einführung der Hauptschule wurden Schulen eines neuen Typs geplant. Ende der 20er Jahre verlagerte sich die Bautätigkeit der Gemeinden auf den Bereich der Öffentlichkeitsbauten, und man wollte neue Schulen bewußt nach modernen Gesichtspunkten bauen und ausstatten. Die Forderung nach Licht, Luft und Sonne waren Grundkriterien, die wiederum die neuen Schulbauten prägten. Unter dieser Voraussetzung entstand auch die Höttinger Hauptschule.

Im Herbst 1928 veröffentlichte man die Wettbewerbsausschreibung für die Planung einer Hauptschule in der Höttinger Au. 43 Architekten reichten ihre Projekte ein. Davon kamen sieben in die engere Wahl. Unter den drei preisgekrönten Entwürfen befand sich auch das Projekt der Architektengemeinschaft Franz Baumann und Theodor Prachensky, welches in einer veränderten Form zur Ausführung kam.

Da anfangs eine gemeinsame Finanzierung der Schule von seiten der Stadt Innsbruck und der damaligen Gemeinde Hötting ins Auge gefaßt wurde, war das Bauvorhaben in der Wettbewerbsausschreibung als Doppelhauptschule mit je einem Trakt für Knaben und Mädchen angegeben.

Als die Gemeinde Innsbruck die Beteiligung ablehnte, mußte die Gemeinde Hötting das Projekt stark reduzieren. In der Folge wurden Grundlagen geschaffen, welche eine Erweiterung im Sinne des ursprünglichen Projektes in einer zweiten Bauphase ermöglichten. Von den neuerlich eingereichten Projekten wurde im Mai 1929 das überarbeitete Projekt Baumann Prachensky zur Ausführung bestimmt.

Am 30. September 1930 begann die von der Gemeinde Hötting beauftragte Fa. Retter mit der Bauausführung. Im Gespräch mit dem Direktor und unter Berücksichtigung schulpraktischer Gesichtspunkte wurde die Planung für die Einrichtung sämtlicher Räume bis ins Detail von Franz Baumann durchgeführt.

Die feierliche Einweihung der Schule fand am 25. Oktober 1931 statt.

Lagemäßig steht die Höttinger Hauptschule am linken Innufer, auf gleicher Höhe mit der Universität, unmittelbar am Fürstenweg. L-förmig umrahmt das Gebäude mit einer bebauten Fläche von 1.790m² und einer Kubatur von 19.180m³ die im Süden ganz der Sonne ausgesetzte Hof- und Spielfläche. Diese ist zum Inn hin gerichtet und umfaßt eine Fläche von 3.729m².

Der dreigeschoßige Baukörper, dessen geometrische Form aus klaren Quadern im Sinne der Neuen Sachlichkeit konzipiert ist, besticht vor allem durch die moderne Linienführung und durch die ruhige lineare und geordnete Fassadenbildung. Die Außenhaut der Schule ist in einem Hellgrau gehalten, das nur durch die gleichmäßigen Fensterbänder und durch den grob gestockten Betonsockel unterbrochen wird. Die horizontalen Strukturen lösen die Flächen des großen Volumens auf und geben dem eher großen Baukörper ein elegantes Aussehen. Der nach Norden vorspringende Baublock im Eingangsbereich fängt den äußeren Raum auf, antwortet auf das Siedlungszentrum von Hötting und macht den Eingangsbereich räumlich sichtbar.

Die aus der Ecksituation herausfließenden Stufen, welche das Straßenniveau mit dem um 2,70 m höher liegenden Erdgeschoß verbinden, und die darüber als Eingangsüberdachung auskragende Betonplatte laden den Besucher förmlich zum Eintreten ein. Die am Eingang ums Eck geführten Betonbänder als Wegweiser, die ursprünglich einer indirekten Beleuchtung dienen, und die im Eingangsbereich viertelkreisförmig nach innen gezogene Fassadenwand steigern abermals die Wegraumdynamik zur Eingangshalle. Man kann hier wohl von einer zwar sehr inszenierten, aber übersichtlichen und gelungenen Eingangssituation sprechen.

Für Transparenz und Lichtdurchflutung in der Halle sorgen die großen Glasflächen an der Eingangsfront und an der Südseite der Halle. Letztere ermöglicht einen Ausblick auf die grüne Hoffläche. Zwei durchgehende Stufen in der Halle und das Podest am Stiegenaufgang schaffen unterschiedliche Niveaus mit starker Bühnenwirkung. Die gut belichteten Stufen im gemauerten Treppenhaus, von einem

verchromten und elegant geführten Handlauf begleitet, erschließen die Obergeschoße, deren Klassenräume zweihüftig an einem Mittelgang angeordnet sind. Zu bemerken ist, daß die Erschließungswege in diesem Gebäude prinzipiell immer zum Licht führen. Die Klassenzimmer mit 65m² Nutzfläche haben einen Luftraum von 225 m³. Eine Fensterfläche von 16 m² transportiert genügend Tageslicht in den Innenraum. Im Inneren wurde bei aller Schlichtheit der Ausstattungsmittel die vollendete Zweckmäßigkeit und repräsentative Größe angestrebt.

Die Turnhalle mit 12 * 25 m bildet einen eigenen Gebäudetrakt und war damals die größte Turnhalle in Tirol.

Die Schule von Baumann ist durchaus für den Weg bezeichnend, der die allgemeine Entwicklung der Baukultur unter dem Grundsatz Neuer Sachlichkeit geprägt hat. Sein Werk zeigt große Sorgfalt im Abwägen der Komponenten Bauzweck, Milieu, Baumittel, Formgebung und Gesinnung.

Basierend auf diesen Beschreibungen wird gemeinsam mit HR Jud vereinbart, bezüglich der Verfassung einer Denkmalbegründung mit den Univ. Ass. Hambrusch, Moroder und Schlorhauser Kontakt aufzunehmen und eine Denkmalbeschreibung zu erarbeiten.



Abb. Fotos: Buch „Franz Baumann Architekt der Moderne in Tirol“ und Festschrift Eröffnung 1932

2.5.3 Efficiency solutions and Heritage Authority comments

Preservation issue surveillance -

CS5 Secondary School NMS Hötting, Fürstenweg13 , A-6020 Innsbruck

In 1928 the municipalities of Hötting and Innsbruck announced an architectural competition for the planned new school building. The architects Franz Baumann and Theodor Prachensky succeeded with their project, strongly influenced by the architecture of Peter Behrens and Bauhaus.

The building complex has both outstanding qualities as structural space and valuable details typical for its constructing-period and therefore was declared historical monument in 2008 following §2 DMSG.

The genuine design concept follows strictly the principles of functional architecture. Well proportioned, mainly horizontal situated volumes in the northwest of the land plot are escalating in a slightly offset tower in the northwest edge: a landmark visible from the street, signing the entrance and marking the most important section of the building. This part locates the hall and main-stairway, the administration in the first floor and the biggest classrooms used for major school events. The architects intended to enclose the school yard with two nearly rectangular wings on the northwest and northeast and a smaller, one storey building in the southwest locating the gym. The schoolyard is orientated to the recreation area in the south alongside the river "Inn", View axes are targeting the landmarks as „Nordkette“, visually from entrance and the classrooms in the northwest, „Patscherkofel“ and the river „Inn“ from the hall and main stairway. This strong interaction between buildings and surrounding landscape is very characteristic for early modern architecture in Tyrol.

All classrooms are opening to the outside with horizontal lines of windows, bringing light and air into the classrooms. Quite new at this time were also the central aisles with classrooms on both sides.

The architecture is determined by a very stringent and straight design, the original colours and surfaces (exterior: pedestal body and gym walls in bus-hammered concrete, walls and ceiling in light grey, wooden furniture, white painted windows): all creating a reluctant, slightly cool but relaxing and open atmosphere for pupils and teachers.

Due to the economic crisis in 1928 only the main wing on the northwest side, following the „Fürstenweg“, and the gym in the southwest were realised between 1929 and 1932. After the annexation of Austria into Nazi Germany in March 1938, air-raid shelters had been constructed in the school-yard.

In the years following WW2 the school was enlarged on the eastside, the originally planned second wing had never been built. Up to the 80thies only very few interventions had been done and therefore a lot of the original structure could be preserved. Not in genuine condition are most of the windows (upper wings now opening to the interior side of the room), the heating central (which has been moved from the ground floor to the roof), the lighting, the door handles, school furnishings (except the built in furniture) and the painting. Also some parts had to be installed because of new building regulations as emergency lighting, fire doors, a rescue stairway and an elevator.

Within 3Encult different interventions improving the energy efficiency of the building were discussed with the Austrian Authority for Cultural Heritage BDA, represented by Landeskonservator Hofrat Dipl.-Ing. Werner Jud, the IIG as owner of the building and the architect.

Since the opening in 1932 not only the methodologies in teaching but also the building codes and guidelines and convenience standards for school buildings have changed, the building therefore has to be adapted to fulfil these demands respecting the interests of cultural heritage.

- Improving of shading, lighting, acoustic, thermal comfort and air quality
- Integration of computer cabling and new technical equipment

Typical construction-flaws due to improper workmanship and a lack of knowledge and experience are causing damages within the construction, which have to be taken in consideration:

- Reinforced concrete: Insufficient covering of the reinforcement, insufficient crack reinforcement, no thermal separation causing severe thermal bridges,
- stone-wood-screeds screeds: magnesia-chlorides as binders are causing severe corrosion of the reinforcement within the floor slabs if the construction gets humid, also due to the lack of a separation layer between screed and bulk
- severe air-leakage of the thermal envelope due to uptight window-, façade-, roof- connection

Within the year's most parts of the genuine interior had been exchanged, only the built in elements still exist and are intended to be restored. The original colours and flooring materials (linoleum) were detected and are intended to be recovered.

One main objective within the discussions between owner, architect and authorities of cultural heritage is the vision of the restored school building, the balance between restoration and adaption to the necessary demands of an up-to-date school preserving the specific atmosphere and characteristics of a building of the 30ties.

Below a list of interventions tried out in the two demonstration classrooms:

Insulation and building tightness

Baseline situation: About 40% of all heat transmissions of the building are passing through the exterior walls. A remarkable improvement of the energetic building performance needs a reduction of the heat transition which can be managed with either interior or exterior insulation.

Authority(BDA):

Exterior Insulation is unacceptable in any case.

In some cases interior insulation is acceptable to make an insulating inner wall if there are no panels or other architectural details. This intervention must be removable without damaging the genuine structure.

Architect:

Facing the limited budget, existing/raising problems in this special case study with building physics (thermal bridges, condensation within the construction) and the risk of interior insulation, causing additional humidity into the support area of the floor slabs nearby the magnesia screeds, the architect prefers exterior insulation. He assumes that if done in a sensible way which does not change the proportions of the building, exterior insulation as a removable wear layer could be an option not only to solve the existing problems of thermal bridges and condensation within the construction but also to preserve the genuine construction from further damages and to keep the genuine heating distribution and radiators in place.

Interventions done

Interior insulation to existing outer walls: Two different solutions are applied and tested.

Room 1: a PUR foam board glued with loam to the wall, with integrated silicate wicks and vapour open plaster, bringing humidity from within the wall to the interior warm side.

Room 2: a wooden frame substructure, filled with blown in cellulose insulation, covered by loam boards and loam plaster.

Air tightness was improved adding plaster/window-connections.

Benefit: reduced heat transition

Disadvantage: thermal bridges can't be solved, risk of condensation within the construction, high costs due to the necessary removing of the heating distribution and radiators, loss of genuine heating distribution, area and volume

Windows and sun shading

Baseline situation: existing windows are only partly genuine, already damaged and generally in a bad state of repair. Existing load bearing steel columns within the window lines, unprotected against fire impact and also severe thermal bridges. Leakages caused by not airtight plaster/windows-connections. The original shading - a roller blind mounted within the two wing layers – is inefficient and damage-prone.

Authority (BDA):

The genuine windows should be preserved.

Due to the already done interventions on the old windows, the effort to repair/restore the old windows is much higher than to rebuild them, so reconstructing them could be a solution in this special situation (but is not a general advice!). The double glazing for the inner wings is acceptable.

The new daylight guiding venetian blinds mounted within the wings are acceptable during the time of measurements. The intervention can't be assessed at the time for the whole building. It can be considered, if it doesn't disturb the buildings main heritage value.

Architect:

Prefers an improved reconstruction of the old windows following the old drawings and in this way receiving a higher quality in a more cost efficient way. Attention has to be paid to the steel columns (I-girders) running vertically through the window lines. In accordance to the new building laws, they have to resist a fire impact of at least 90 minutes and have to be protected either by fire protecting coat or plasterboard.

In the eventuality of an exterior Insulation, the windows have to be shifted to the outside, keeping the proportions of the existing window embrasures.

Interventions done

Room 1: Demounting/Repairing/restoring/improving/mounting of the genuine box-type windows. The upper outer wings were rebuilt according to the investigated genuine state of construction.

To reduce the leakages and heat transition in the layer of the inner wings additional window seals were added and the thermal quality of the glazing (double glazing instead of existing single glazing) improved.

Where the windows had been demounted, the steel columns between the windows elements were painted with a fire protecting coat, capable to resist 90 minutes of fire impact and also isolation added to reduce the thermal bridges.

The old blinds were replaced by new daylight guiding venetian blinds, supporting the artificial lighting in an energy efficient way.

Room 2: The old windows were painted, the roller blinds repaired.

Benefit: regain of the genuine optic and function of the exterior upper wings, reduced heat transition, reduced solar gains, efficient use of daylight

Disadvantage: difficult adjustments of the daylight guiding shadings, thermal bridges caused by steel columns can only be solved, if they are situated within the warm side of the construction, risk of condensation within the construction especially if not airtight, high costs due to the necessary demounting/mounting of the windows, additional weight of the double glazing could overstrain the genuine Iron strap fittings of the windows, these should be reinforced.

Heating and cooling

Baseline situation: The measured heating demand, being about 25% higher than the calculated one, resulted mainly out of not adjustable room temperatures, caused by the enormous thermal mass (about 400-500 kg) of the radiators with a flow temperature of about 85 degrees Celsius. So in winter, room temperature was regulated by opening the windows. This caused very dry air and very uncomfortable conditions for pupils, having their seats near the window line. In summer especially on the west facades the solar gains are high, resulting in overheating. The heating central is placed under the roof, providing not only the school but also the public swimming bath in the neighbourhood. Heat losses are high. It is intended to separate the swimming bath from the heating central and to construct a new heating central for both: the actually new built school SPZ in the south of the gym and the old school.

Authority:

The genuine tube-radiators are essential elements of the interior design and must be preserved.

Architect:

To provide pupils and teachers with an optimum setting for learning in the modernized rooms, the existing problems with dry air and discomfort should be improved: the radiators, essential element for the genuine interior design must be optimised to fit to the demands of comfort. Within the thermal refurbishment the flow temperature should be lowered to a level, which allows a feasible integration of renewable energies. The thermal mass of the radiators should be reduced. Also the thermal mass of the floor slabs should be used as a thermal buffer to prevent expensive active cooling.

Interventions done

In both rooms the heating distribution was separated from the main distribution line: a heat exchanger and circulation pump was interposed between main distribution line and separated heating circuit to simulate lower flow temperature.

The ceilings were kept free from interventions (as acoustic drywall suspended ceilings) to keep them in use as thermal buffer.

Room 1: inlets mounted in the radiators, reducing the volume of the heating water to a third, improving the adjustability, flow temperature lowered to 45°C adapted to reduced heat demand (interior insulation and improved thermal quality of window line),

Room 2: flow temperature 55°C adapted to reduced heat demand (only interior insulation)

A replacement of the old heavy tube radiators was discussed, a new sample tube radiator ordered but not deliverable in the needed construction length of about 8m due to static problems (fixed diameter of the tubes).

Benefit: increased comfort, improved adjustability, reduced heat losses

Disadvantage: high efforts, high costs, still high thermal masses of the radiators.

Ventilation

Baseline situation: insufficient natural ventilation through windows. Measurements have brought up, that even with leakages the indoor air quality during lessons is insufficient and mechanical ventilation necessary to fulfil the obliged value with a maximum of 1500 ppm CO₂.

Authority:

Window is designed with the intention to be opened. An additional ventilation system with the least possible impact on the genuine structure (using f. ex. secondary rooms for distribution) is conceivable but has to respect the high quality of the genuine interior architecture. If the necessary documentation is obtained, it can be considered, if it doesn't disturb the buildings main heritage value.

Architect/Scientist:

Architect: To provide pupils and teachers with an optimum setting for learning in the modernized rooms, the existing problems with air quality should be improved.

Scientist: Proposes a cascade ventilation system, using the space of the old heating central under the roof, using the main stairway and the corridors, bringing in the fresh air, guiding/collecting the waste air through pipes situated in secondary rooms as wardrobes, washrooms, toilettes, up to the roof, using a heat exchanger to warm up the fresh air.

Interventions done

Room 1/Room 2: Installing of ventilators with integrated silencers, textile hoses for air distribution within both classrooms.

Wardrobe: Installing of an exhaust ventilator to simulate the circulation of their streams and pressure differences within the corridor.

Benefit: increased air quality, reduced heat losses

Disadvantage: costs, some impact on genuine interior design.

Electricity/Lighting

Baseline situation: existing electrical installation is not in accordance with technical standards and guidelines and not capable to fulfil the demands of new technical equipment and common IT solutions due to new methodologies in teaching. Insufficient lighting-conditions in the classrooms on two-third of the tables (measured values of about 150 Lumen, obligation for classrooms minimum of 300 lx)

Authority:

The intervention can't be assessed at the time. If the necessary documentation is obtained, it can be considered, if it doesn't disturb the buildings main heritage value.

Architect/Scientist:

Architect: To provide pupils and teachers with an optimum setting for learning in the modernized rooms, the electrical installation has to fulfil the demands and has to be flexible enough to implement further possible needs. Energy efficient solutions should be preferred.

Interventions done

In both classrooms IT-electrical installations were added as a provisional arrangement, the existing electrical installation supplemented.

Room 1: The old blinds were replaced by new daylight guiding venetian blinds, supporting the artificial lighting in an energy efficient way. A new lighting system was installed, using LED balanced colour lamps and wall washer.

Room 2: The old blinds were kept. A new lighting system was installed within suspended acoustic drywall absorber elements, using energy efficient fluorescent tubes of the newest energy efficient generation TC-L and 6*2 x 24/49/54 W T16 tubes and wall washer.

Benefit: demands fulfilled, improved lighting situation, reduced electricity costs

Disadvantage: character of provisional arrangement, costs of LED balanced colour lamps, some impact on genuine interior design.

Acoustics

Baseline situation: very long reverberation times, lack of understandability

Authority:

The intervention can't be assessed at the time. It can be considered, if it doesn't disturb the buildings main heritage value.

Architect:

Improving of understandability is absolutely necessary for an optimum setting for learning.

Interventions done

Room 1: bio-fiberabsorbers mounted on the most inner third of the ceiling (rest of ceiling used for reflecting daylight)

Room 2: dryboard absorbers combined with lighting solution

Benefit: acceptable reverberation times in both classrooms

Disadvantage: some impact on genuine interior design

2.6 CS6 Warehouse Potsdam, House Dresden, House Freiberg, House Görlitz (Germany)

2.6.1 LCS-Team/s

Case study leader/ 3ENCULT responsible partner:
Ayman Bishara, Rudolf Plagge TUD (P09)

1-Test House Speicherstadt Potsdam (Magazin 3)

Owner: Speicherstadt GmbH
Alleestraße 9
14469 Potsdam
Architect: Kühnel Architekten
Prof. Dr. Holger Kühnel
Große Weinmeisterstraße 9, 14469 Potsdam
Monument Conservation: Untere Denkmalschutzbehörde
Hegelallee 6-10, Haus 1, D-14467 Potsdam

2-Test House in Loschwitzer Straße „Gründerzeit Villa“

Owner: Dr. Frank Zinsser
Meißnerstr. 29
01589 Riesa
Architect: Architektur- und Planungsbüro Atea GmbH, Riesa
Moritzer Str. 17
01589 Riesa, Sachsen
Monument Conservation: Dresden Denkmal Blasewitz
Amt f. Kultur und Denkmalschutz, Kulturrathaus Zi. 26
Herr Schumann
Königstrasse 15
01097Dresden
dschumann@dresden.de
0351 / 488-8953

3-Test House in Freiberg, Donatsgasse 21:

Owner: H. Neuhaus
Donatsgasse 21
09599 Freiberg
Architect: Architekturbüro Gerschler
Mönchsstraße 3
09599 Freiberg
Monument Conservation: Dezernat I - Stadtentwicklung und Bauwesen
Amt: Bauaufsichtsamt
Sachgebiet: Untere Denkmalschutzbehörde
Petriplatz 7/8, 09599 Freiberg

4-Test House in Görlitz:

Owner: Dipl.-Ing. Janet Conrad

Architect: Dipl.-Ing. Janet Conrad

Handwerk 15

02826 Görlitz

E-Mail: janet@altstadtatelier-conrad.de

Monument Conservation: Landesamt für Denkmalpflege Sachsen

Schloßplatz 1

01067 Dresden

2.6.2 Round table, additional information

For all case studies accompanied by TUD it is stated by TUD that all solutions were always in very close collaboration between the engineers of TUD and the representatives of monument conservation developed. All solutions were always discussed and agreed on the round table. Written documents of that or post evaluation by conservators are not available.

Additional information on Energy efficient renovation for historical buildings was contributed by TUD.

Energy efficient renovation for historical buildings

Results, energy savings and monuments Compatibility (TUD)

1- Investigation methods, tools, boundary conditions

The measures to increase energy efficiency at the monument have been determined by voting in the working group. These interventions must be assessed in terms of energy and protection of historic monuments.

The methodology of the investigation requires a two-step approach. First step allows an assessment of the energy efficiency of the measure and second step allows an evaluation of the resulting consequences on the monument. These different evaluation methods of the respective areas of expertise describe the following section.

In addition, a comparative analysis alone would provide however an isolated sectoral results according to the key criteria of energy efficiency and conservation. That would be neither practical requirements nor parent environmental objectives relevant. Therefore, further criteria were included for assessing the structural design and functionality.

However, this extended assessment could only partial insure in the frame of the case study, because it requires significantly higher time and effort data, and also advanced interdisciplinary expertise.

Fig.1 below shows once the basis mentioned evaluation matrix with changes and enhancements made in the course of the study. The abscissa shows the list of selected investigated eleven evaluation criteria, whether the ordinate contains the measures examined.

Kriterienklassen	Ökolog. Verträglichkeit			Betriebskosten Energie			Bauwerk, Konstruktion			Funktionale Qualität			Denkmalverträglichkeit											
	CO ₂ -Bilanz	Ressourcen	Primärenergie	Endenergie	Beleglichkeit	Werthaltigkeit	Schadensrisiko	Gebrauchswert	Substanz	Erscheinungsbild	Reversibilität	CO ₂ -Bilanz	Ressourcen	Primärenergie	Endenergie	Beleglichkeit	Werthaltigkeit	Schadensrisiko	Gebrauchswert	Substanz	Erscheinungsbild	Reversibilität		
Bewertungskriterien	Einheit	Erfüllungsgrad	Erfüllungsgrad	Erfüllungsgrad	Erfüllungsgrad	Erfüllungsgrad	Erfüllungsgrad	Erfüllungsgrad	Erfüllungsgrad	Erfüllungsgrad	Erfüllungsgrad	Erfüllungsgrad	Erfüllungsgrad	Erfüllungsgrad	Erfüllungsgrad	Erfüllungsgrad	Erfüllungsgrad	Erfüllungsgrad	Erfüllungsgrad	Erfüllungsgrad	Erfüllungsgrad	Erfüllungsgrad	Erfüllungsgrad	
M A S S A H M E N Effekte:																								
Optimierung Gebäudehülle und Anlagentechnik																								
Keller	1	Perimeterdämmung, IG-Außenwand																						
	2	Unterer Abschluss, KG-Decke/EG-FB																						
Dach	3	Oberste Geschosdecke																						
	4	Zwischensparrendämmung																						
	5	Aufsparrendämmung																						
Fassade	6	WDVS (verputzt) Straßenseite																						
	7	WDVS (verputzt) Hofseite																						
	8	hinterlüftete Verschalungen Straße																						
	9	hinterlüftete Verschalungen Hof																						
	10	Wärmedämmputz Straßenseite																						
	11	Wärmedämmputz Hofseite																						
	12	Innendämmung																						
	13	Mehrschalige Fass./Kerndämmung																						
	14	VIP, TMD																						
Lüftlichkeit	15	Abdichten (Aufarb./) Fenster-Konstr.																						
Fenster	16	Neue Fenster (WSV) Straßenseite																						
	17	Neue Fenster (WSV) Hofseite																						
	18	Zusatzfenster																						
Lüftungsanlage	19	Abdichtung-mech. Lüftung mit WRG																						
Haustechnik	20	Effizienz der Heizungsanlage																						
Kombination	21	Maßnahmen 1, 2, 3a, 4a-f, 5a-e, 6																						
Nutzung von Energie-Erzeugungspotentialen																								
Solarthermie	22	Dach Straßenseite	7a																					
	23	Dach Hofseite	7b																					
	24	Fassade Straßenseite	7c																					
	25	Fassade Hofseite	7d																					
Photovoltaik	26	Dach Straßenseite	8a																					
	27	Dach Hofseite	8b																					
	28	Fassade Straßenseite	8c																					
	29	Fassade Hofseite	8d																					
Kraft-Wärme-K.	30	Mini BHKW	9a																					
(KWK)	31	Nah-/Fernwärme mit KWK	9b																					
Geothermie	32	Erdwärme mit Wärmepumpe	10																					
Quartiersbezogene Faktoren																								
Externe Faktoren																								
1) Die Systematik dient der Einordnung der Untersuchungsergebnisse in eine Gesamtbetrachtung; diese kann im Rahmen der Untersuchungsergebnisse in einigen Kernausagen angedeutet werden, sie ist jedoch für eine weitergehende Betrachtung (volkswirtschaftlicher, energiepolitischer, ökologischer und kultureller) Effekte erforderlich.																								

Fig. 1 Evaluation matrix with the establishment of evaluation criteria (abscissa) and examined measures (ordinate)

1.1 Methodology of building climate modeling, boundary conditions

The computerized building simulation was used for as a tool for assessing the measures from the energy viewpoint, in order to determine the building energy demand in different variants. The ratio between the calculated energy demands of each variant and the ratio of the output model allows the determination of the percentage of each potential savings through the implementation of the investigated method.

- Tool - building simulation
- Calibration of the building model
- Creating efficient building simulation models
- Documentation of input parameters contains: user profiles and zoning, setting the target room air temperatures, Per capita living space, Material properties and constructions, thermal bridges, ventilation, Energy sources and systems engineering und Climatic conditions (weather data)

1.2 Methodology of historic preservation assessment

Task of conservation, it is not only to provide for the preservation of a certain historical appearance. Important - but difficult - is also to ensure the long-term preservation of the original structure as possible in order to deliver for the future generations not only images, but culture monuments in all their visible and material witness- and information density.

Measures to improve the energy efficiency of cultural monuments must therefore meet three conditions:

- in intervention the asset preservation must be ensured.
- The appearance may not be affected permanently and significantly (defaced).
- Interventions should be possible additive nature in order to be able to undo again without any losses.

1.3 Methodology of the building constructive assessment

The procedure for assessing cultural heritage preservation aspects was used in a similar form to assess other criteria. According to the expert panel in LfD, a similar colloquium was held at the Institute of Building Climatology on 21thApril 2010 to consult together, how the influence of the examined measures must be assessed on the risk of damage of the entire structure.

2- Case groups and case studies

Determination of case groups: The energy demand of a building mainly depends on its geometric shape and size, on the construction of the components as well as on the respective location conditions and terms of use.

2.1 Definition of case groups

2.2 Collection and classification of case studies

2.3 Description of the case studies

3- Survey on experiences with unrealized renovations

3.1 The aim of the survey

3.2 Execution

3.3 Result of the survey

4- Evolution criteria

The evaluation criteria under investigation were stated. The foundation therefore were the, during the work further developed, complemented and differentiated, assessment matrix which is shown by figure 2. The explored measures are already there confronted with the evaluation criteria.

The explored measures are already there confronted with the evaluation criteria. The results of the study included the tables in annex 5 - Integrated assessment matrix, each individually considered for all case groups. For a comprehensive evaluation of measures to increase the energy efficiency of heritage buildings a variety of other generally relevant aspects occur next to the energetic and cultural heritage preserving criteria. These are not to be assessed in the context of the study, though at least they should be kept in sight.

The general ecological compatibility, long-term impact on the overall building construction and the user friendliness belong thereto. To assess the measures according to the criteria described here, two methods have been used, which methodologies are already described in section 5. While the energetic savings potential and the improve of the comfort of the measure was percentage calculated, the evaluation of all following aspects was made on the basis of other criteria using a five-step evaluation procedure based on the method of cost-benefit analysis.

4.1 Ecological compatibility

For assessing the environmental compatibility of the measures three criteria were positioned. In addition to the calculated primary energy savings (QP), the CO₂ balance respectively the in the construction material contained grey energy over the entire life cycle²¹, and the consumption of resource of each measure are to be condiered.²² Only the primary energy savings could be determined primarily in the examination at hand. For the other criteria only occasional statements could be made were, because a deeper analysis would be needed for that.

4.1.1 Savings potential of Primary energy,

4.1.2 CO₂ emissions and resource consumption,

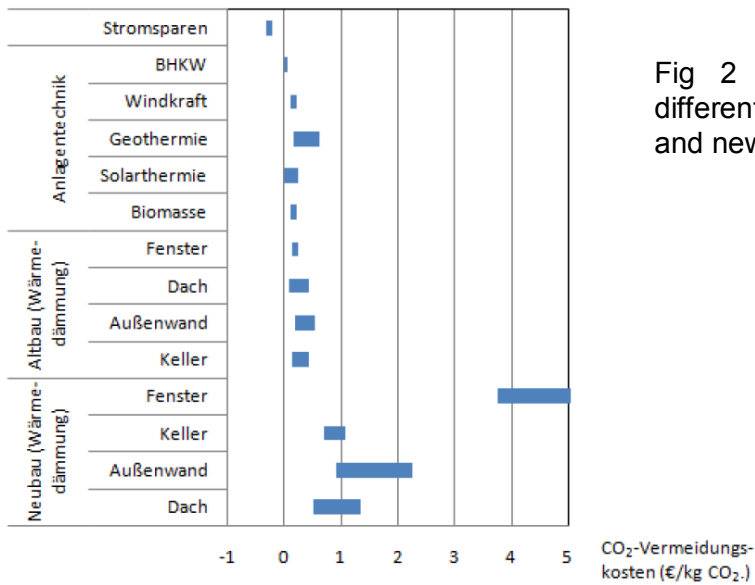

Fig 2 Energy abatement castes of different measures in comparison (old and new)

4.2 Energy purchase cost of final energy (Economical Quality)

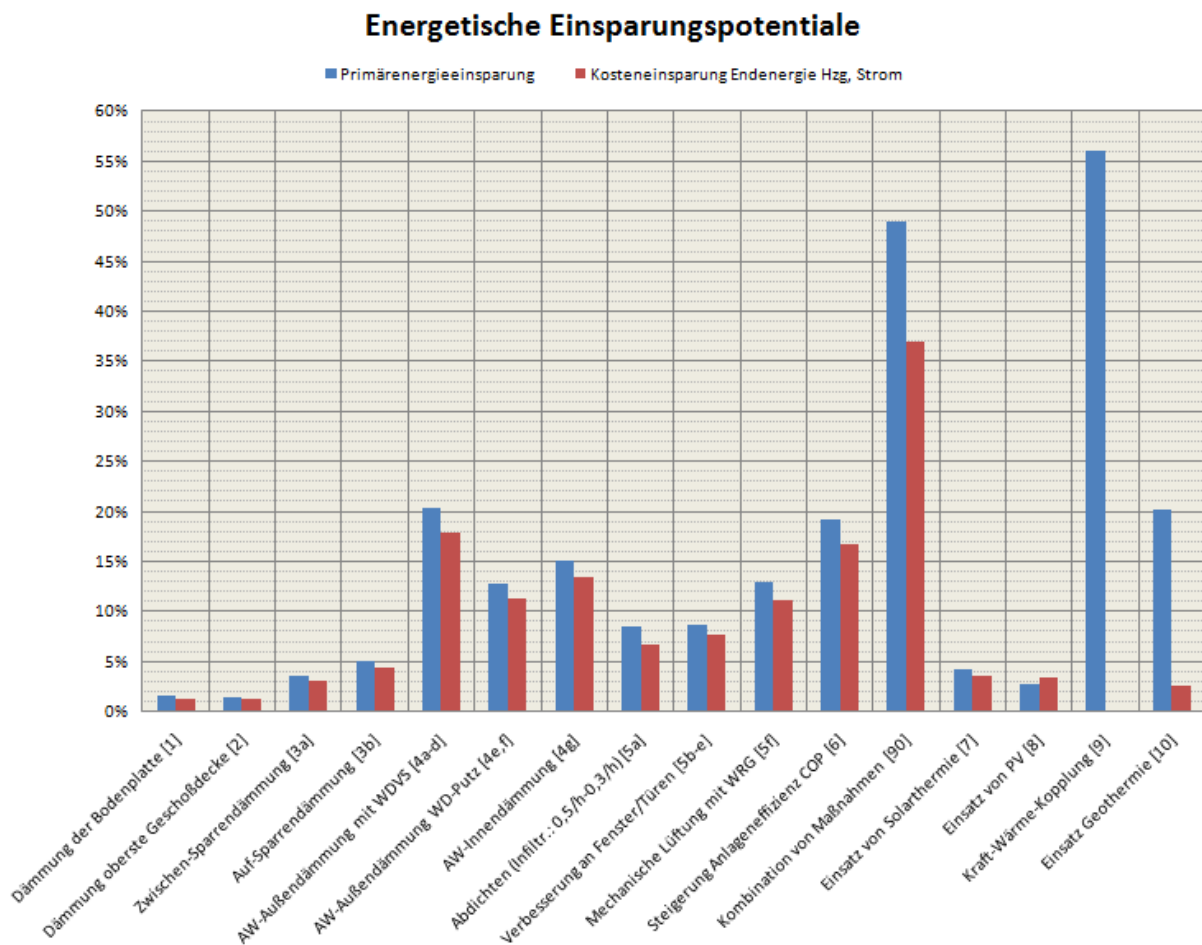
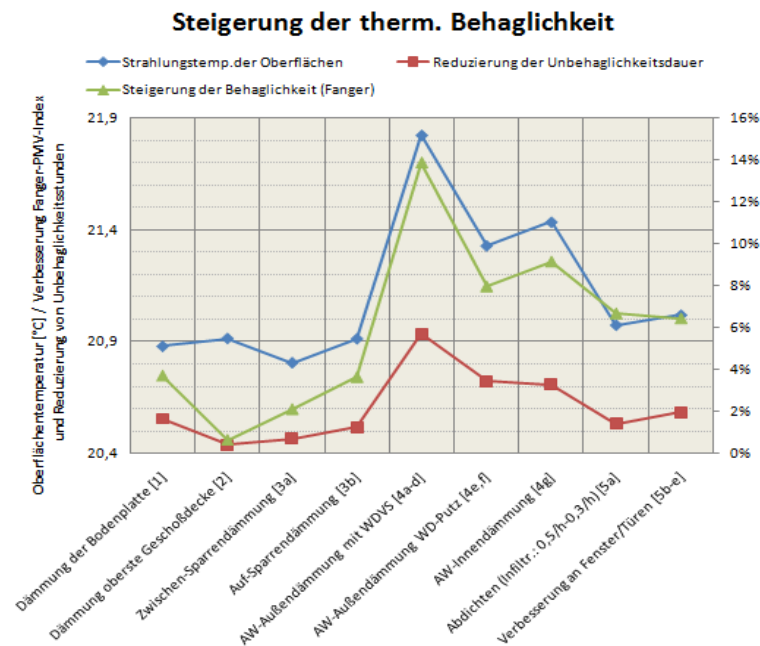

Fig 3 Average savings of primary energy (QP) and costs for energy consumption (gas and electricity)

4.3 Criteria of technical quality - building and construction

- Assessment of comfort



Improvement of thermal comfort: increase the brightness temperatures of the surrounding component surfaces, percentage increase in the Fanger –PMV- index and reducing the number uncomfortable hours, averages over all case studies

- H'T value - improving the heat transfer of the building envelope

The graph below summarizes the results of the two most important criteria as averages over all case groups together again. On the left side it shows the potential savings in costs for the purchase of final energy (heat and electricity) and this is compare the results of the assessment of the compatibility of the monument measures.

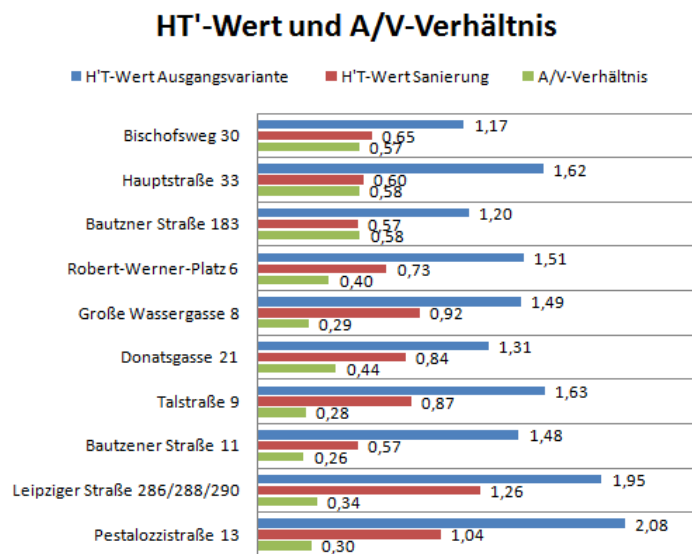

Comparison of H'T values of the case studies, before and after restoration

- Impairment / sustainability
- Damage risk, predictability, long-term consequences,

4.4 criteria of functional quality

4.5 preservation criteria

- Material witness value: impact on the traditional substance of the building, loss of substance
- Creatively of design value
- Reversibility

5- Measures

5.1 General assumptions, approach

5.2 Output variant (variant 0)

5.3 Insulation of Basement ceiling or floor plate (option 1)

5.4 Insulation of the top floor ceiling (variant 2)

5.5 Insulation of the roof (Variant 3)

- Insulation of the roof with insulation between rafters (variant 3a)
- Insulation of the roof using rafter insulation (version 3b)

5.6 Insulation of external walls (version 4)

- Insulation of external walls behind wood paneling (version 4c + d)
- Outer wall interior insulation with insulating plaster (4e variant + f)
- Interior insulation of the external walls (variant 4g)

5.7 building caulk, reducing of infiltration (version 5)

- Infiltration- air change rate of 0.5 to 0.3 / h reduced (version 5a)
- Replacement of windows and doors, including sealing (variant 5b + c)
- Installation of an additional window level (variant 5d + e)
- Mechanical ventilation with heat recovery (variant 5f)

5.8 Reduction of investment losses

5.9 Combination of saving measures

5.10 Efficient heat generation and renewable energy

- Solar thermal systems (variant 7a + b)
- Photovoltaic systems (variant 8a + b)
- Heat power combination ((KWK) (variant 9)
- Geothermal (Variant E10)

5.11 Summary of the comparison of measures

6- Results

Savings potential and monuments Compatibility

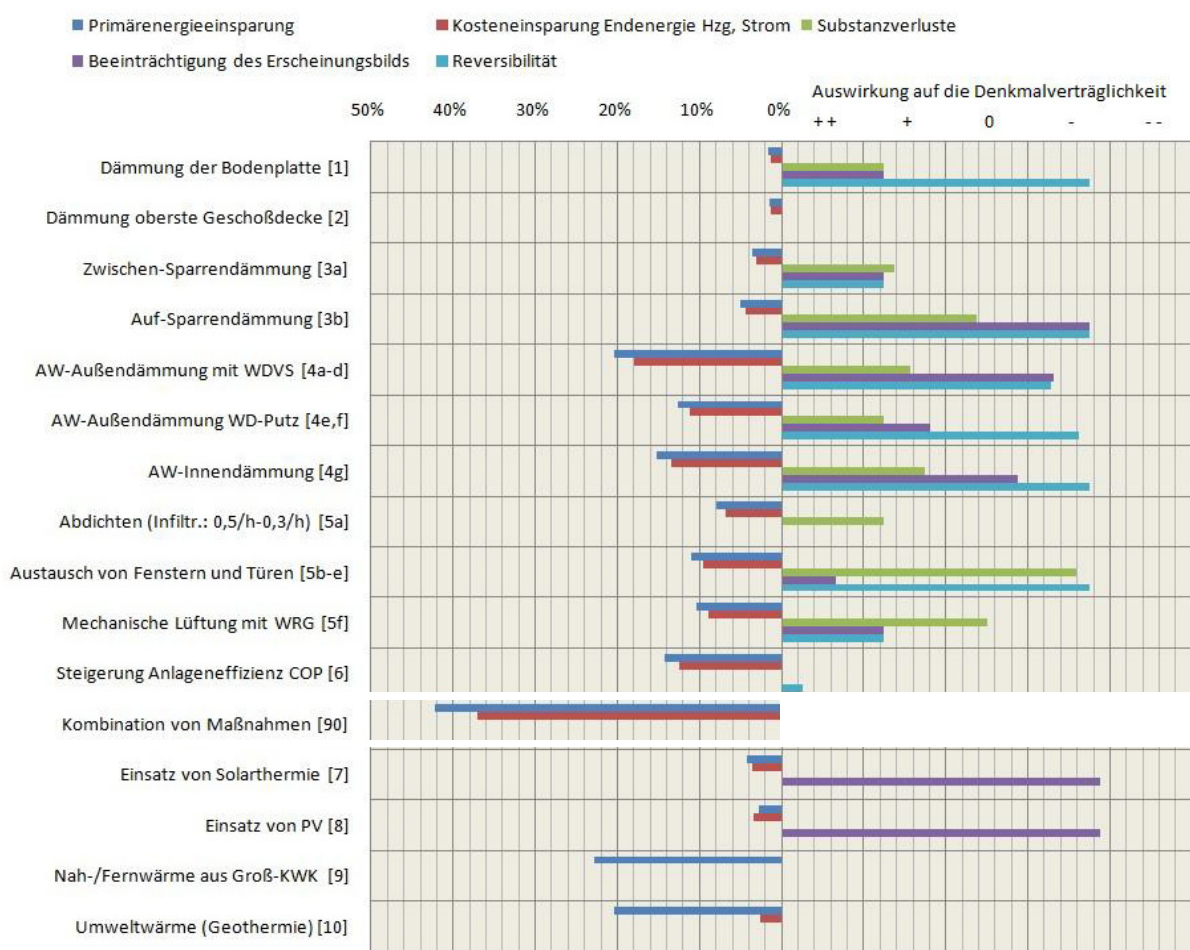

Savings potential and monuments Compatibility

7- Discussion and conclusion

Several pilot projects have been carried out in Germany in recent years for energetic renovating and accompanying measurements. In view of the increase in energy efficiency, they all show high potential for savings in existing buildings. Similarly high savings could not be detected in the present study because the selected construction (except pilot project Freiberg, Donatsgasse 21) regarding the energetic standards remains considerably behind in parts. Insofar this study reflects the currently implemented standard by which such savings, as with individual pilot projects, are not achieved.

Technological advancements and new developments of materials, systems and technologies allow a more efficient optimization of the building envelope, both by reducing heat losses as well as the increase of heat gains and the use of renewable energy (Solarthermie, PV and others). Nevertheless, we are apparently just at the beginning of a development in which course the energy demand of buildings will fall strongly in the coming years, to buildings that generate more energy than they use during normal operation. [63] Through the participation in the EnOB project [70], the Institute of Building Climatology is directly involved in these developments and has experience out of more than 30 demonstration projects of different building types.

Merging the building data and parameters, typing

For merging the results a table (annex 1 - typology) was developed in which the parameters and assessments of the computationally examined individual examples were matched with the general statements of the survey and merged to case group-specific statements. For each of the examined case groups a table is created.

The left column contains systematically structured lines for the building parameters, the measures to be assessed and the effects on the monument or shape values, and also some characteristics of the frequency/relevance of each type. In the right column follow classification of results. When multiple samples were examined, a range for each group of cases can be specified here. External information can be inserted here through a comparison with results in the specialized literature if necessary.

Collocation of the results in the evaluation matrix

The integrated assessment matrix (Annex 2), which has been filled once for each case group, opposes the potentials and effects of the individual measures for the increase of energy efficiency, shows the interlocking of economical, ecological and socio-cultural issues and thus allows the reader a consideration and interpretation process. This is the formulation of guidelines with recommendatory character for each measure supports.

A summary of all the individual results of the evaluation of the measure to an average result, which aim are benefit analyses for example, allowing decisions in the economic field, were neither aim of the investigation nor possible to implement, because negative effects may annul each other in such evaluation and thus distort the results.

With the chosen path here, as far as known, methodological new land is taken for the cultural heritage preserving evaluation of measures in a larger effect context.

This development and testing of appropriate evaluation procedure seems appropriate given the increasing regulation pressure in the field of building renovation, the energetic enhancement and the cultural heritage preservation testing of suitable assessment methods, even if it is foreseeable that no scientifically completed methodology can be submitted for the purpose of this pilot study.

The valuations are not intended in the sense of a simple addition of points. The with colour symbols (red: usually not recommended, yellow: to check, to check but tend to

be positive, to check but tend to be negative, green: usually harmless) as well as with numerical parameters (percentage savings or improvement) filled matrix is not mandatory to obtain verifiable entries on all points. Nevertheless it should illustrate the complex interrelated issues in an integrated overall evaluation.

Freiberg

measure			substance	appearance	reversibility
1	Insulation foundation slab/basement ceiling	a) Main building b) Annex above thermal storage	++	no remains of the historic floors - mainly concrete floor, terrazzo tiling from the 70s of the last century	o
2	Insulation first floor ceiling	a) Buffer zone ceiling above ground floor	+	wooden beam ceiling heavily damaged, planking not able to take load, flooring from the 70s of the last century, dismantling planking, fixation and conservation beams	o
3	Over and between rafter insulation		+	roof construction and casing heavily damaged, fixation and renovation roof construction, new casing	+
4a	Insulation of the exteriorwand with WDVS	a) Annex ground floor	+	heavily damaged mixed masonry, plaster heavily damaged, large-areal non-existent	+
4b	Insulation of the EW with Vorsatzschale	a) Annex 1st floor	+	Irreparable damages of the roof construction	+
4c	Insulation of the EW with interiorinsulation	a) Eave/ balustrade attic floor	-	heavy damages, eave plate with irreparable damages, plaster partially not-existent, support of masonry, losses mural paintings	-
4d	House in house concept main building		1	heavy damages of the interior and exterior plaster, preservation of the existing material evidences	+
4e	Prevention of thermal bridges		-	masonry of the back EW affected	+
5a	Reduction of Infiltration-air change		1	no influence	++
5c	Substitution/improvement windows/doors		-	streetfaçade windows from the 70s of the last century heavily damaged single-glazed windows	+
5c	Substitution/improvement windows/doors	b) Yard	-	heavily damaged single-glazed windows, total loss	++
5c	Mechanic ventilation system with heat recovery		o	partially large breaches	+
6	Improvement facility efficiency		++	chimney with heavilyen damages zurückgebaut	++
7	Solarthermal facility on roof streetside		++	crown-tile roof, heavily occlusive	-
8	Photovoltaik-facility on roof		++	crown-tile roof, heavily occlusive	-
9	close / district heating				
10	geothermal				

A	A	Primary energy (CO2) emissions	consumption costs Final energy	substance	appearance	reversibility
1	1 Insulation foundation slab/basement ceiling	1,9%	1,8%	100,0%	100,0%	100,0%
2	2 Insulation first floor ceiling	2,4%	2,2%	75,0%	0,0%	75,0%
3	3 Over and between rafter insulation	4,0%	3,7%	75,0%	12,5%	75,0%
4a	4a Insulation of the exteriorwand with WDVS	4,2%	3,9%	75,0%	25,0%	75,0%
4b	4b Insulation of the EW with Vorsatzschale	33,3%	30,7%	75,0%	100,0%	25,0%
4c	4c Insulation of the EW with interiorinsulation	33,3%	30,7%	25,0%	50,0%	25,0%
4d	4d House in house concept main building	22,0%	20,3%	0,0%	50,0%	25,0%
4e	4e Prevention of thermal bridges	26,6%	24,5%	25,0%	50,0%	25,0%
5a	5a Reduction of Infiltration-air change	5,8%	5,3%	0,0%	0,0%	100,0%
5c	5c Substitution/improvement windows/doors	9,7%	8,9%	25,0%	25,0%	0,0%
5c	5c Substitution/improvement windows/doors	9,7%	8,9%	25,0%	0,0%	75,0%
5c	5c Mechanic ventilation system with heat recovery	7,0%	6,4%	50,0%	25,0%	75,0%
6	6 Improvement facility efficiency	17,1%	15,7%	100,0%	0,0%	100,0%
7	7 Solarthermal facility on roof streetside	6,4%	5,9%	100,0%	100,0%	100,0%
8	8 Photovoltaik-facility on roof	4,3%	5,6%	100,0%	100,0%	100,0%
9	9 close / district heating	28,8%	0,0%	0,0%	0,0%	100,0%
10	10 geothermal	25,7%	3,5%	0,0%	0,0%	100,0%
		55,9%	51,5%	0,0%	#DIV/0!	#DIV/0!
			10,4%	von: 0,0%		
			8,2%	bis: 0,0%		

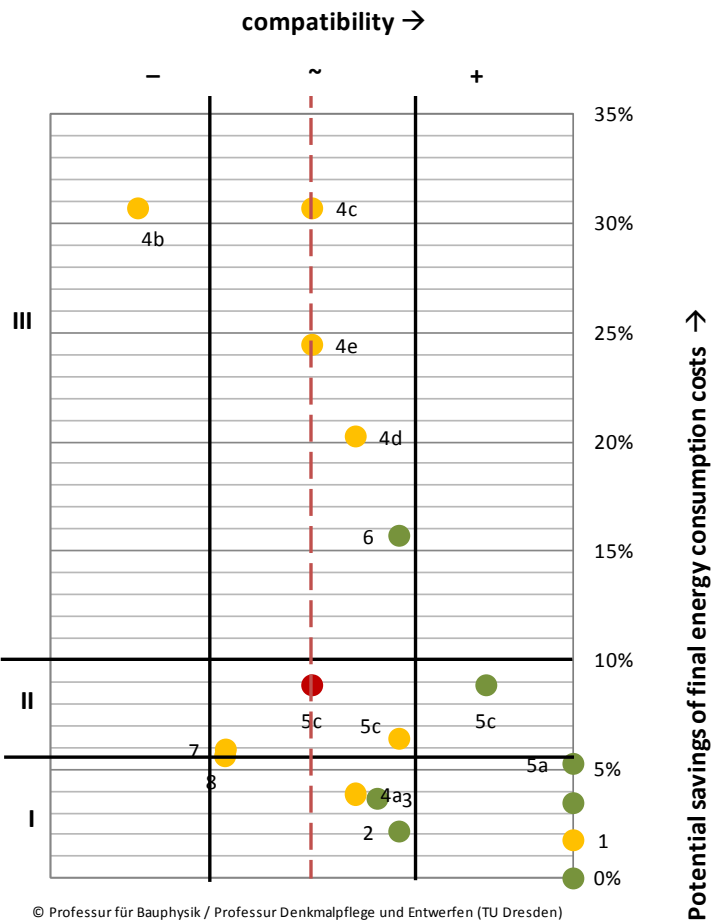
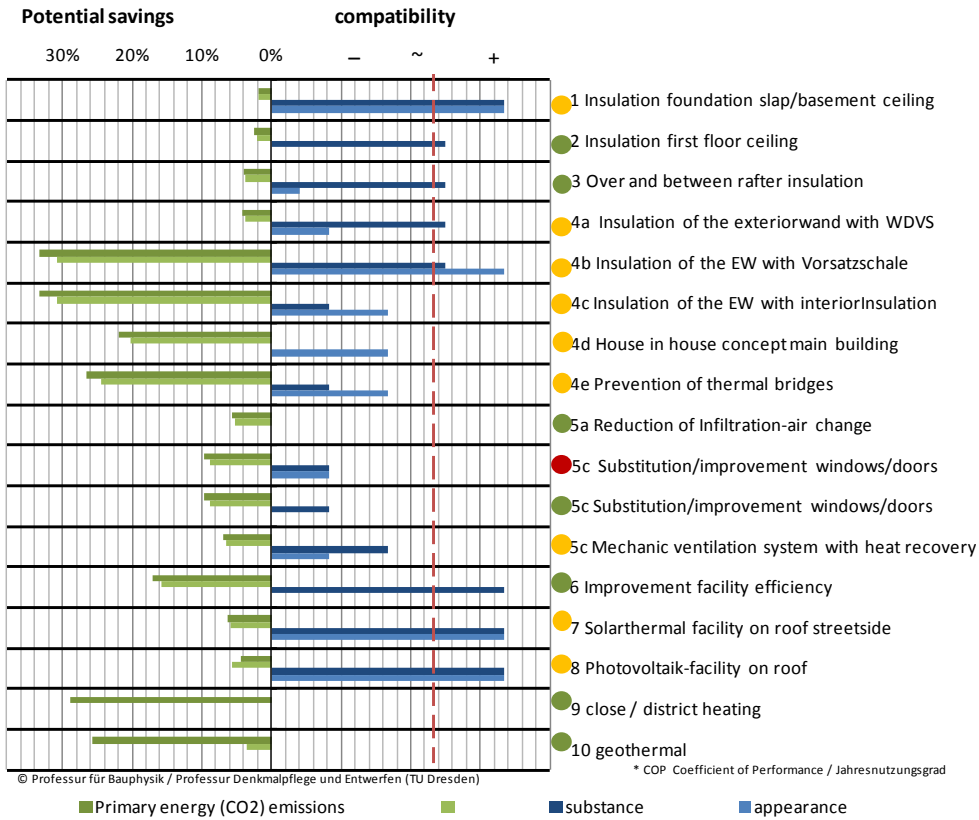

Görlitz

	Energieeinsparung	Denkmalverträglichkeit	Substanz	Erscheinungsbild	Reversibilität
1	1,0%	41,7%	-15%	-15%	-8%
2	0,2%	100,0%	-30%	-30%	-30%
3a	1,7%	70,8%	-19%	-23%	-23%
3b	2,0%	37,5%	-19%	-8%	-8%
4a,b	6,1%	50,0%	-23%	-15%	-8%
4c,d	6,1%	54,2%	-23%	-15%	-11%
4e,f	4,3%	62,5%	-23%	-26%	-8%
4g	5,1%	41,7%	-15%	-15%	-8%
5a	4,1%	91,7%	-23%	-30%	-30%
5b,c	5,2%	33,3%	-4%	-26%	0%
5d	5,2%	91,7%	-30%	-30%	-23%
5e	7,1%	66,7%	-15%	-23%	-23%
6	5,8%	100,0%	-30%	-30%	-30%
7	2,4%	75,0%	-30%	-8%	-30%
8	1,9%	75,0%	-30%	-8%	-30%
9	4,9%	100,0%	-30%	-30%	-30%
10	4,9%	100,0%	-30%	-30%	-30%

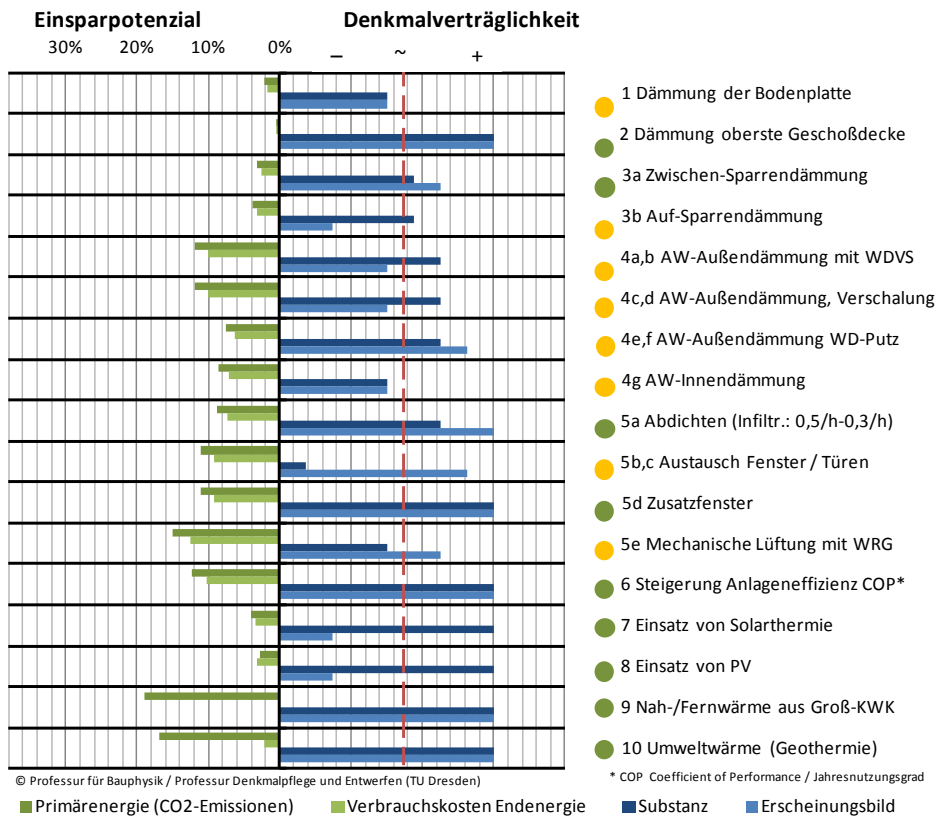

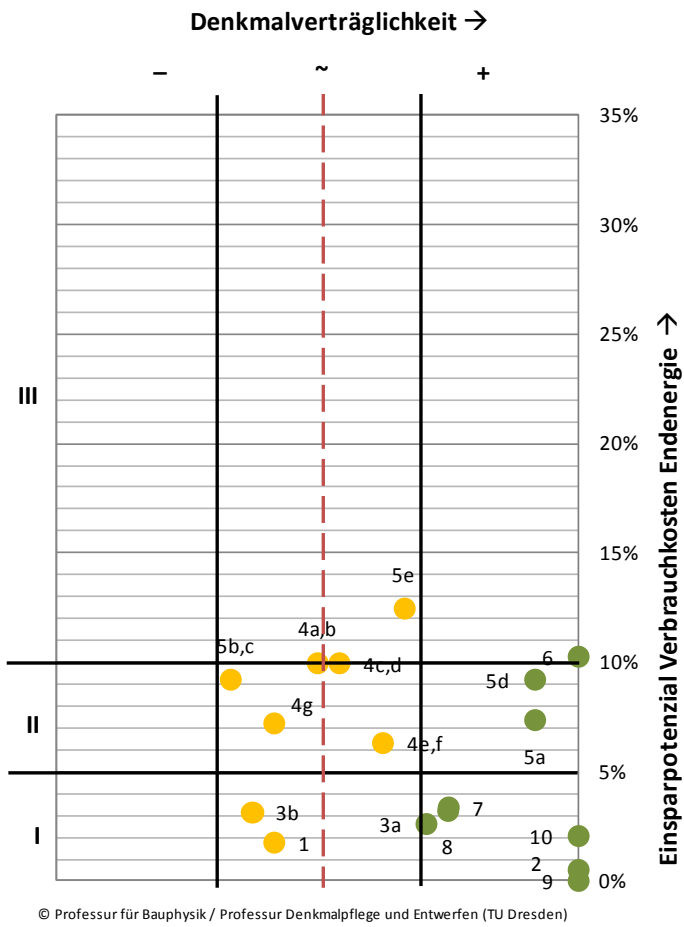

Dresden

	Energieeinsparung	Denkmalverträglichkeit	Substanz	Erscheinungsbild	Reversibilität
1	0,8%	75,0%	-30%	-30%	-8%
2	1,0%	100,0%	-30%	-30%	-30%
3a	1,8%	75,0%	-23%	-23%	-23%
3b	2,0%	33,3%	-15%	-8%	-8%
4a,b	6,8%	54,2%	-23%	-11%	-15%
4c,d	6,8%	50,0%	-19%	-11%	-15%
4e,f	3,8%	52,1%	-23%	-17%	-8%
4g	4,6%	50,0%	-23%	-15%	-8%
5a	4,3%	91,7%	-23%	-30%	-30%
5b,c	6,5%	27,1%	0%	-24%	0%
5d	6,5%	91,7%	-30%	-30%	-23%
5e	7,4%	66,7%	-15%	-23%	-23%
6	6,0%	95,8%	-30%	-30%	-26%
7	3,1%	85,4%	-30%	-17%	-30%
8	2,4%	85,4%	-30%	-17%	-30%
9	5,1%	100,0%	-30%	-30%	-30%
10	5,1%	100,0%	-30%	-30%	-30%

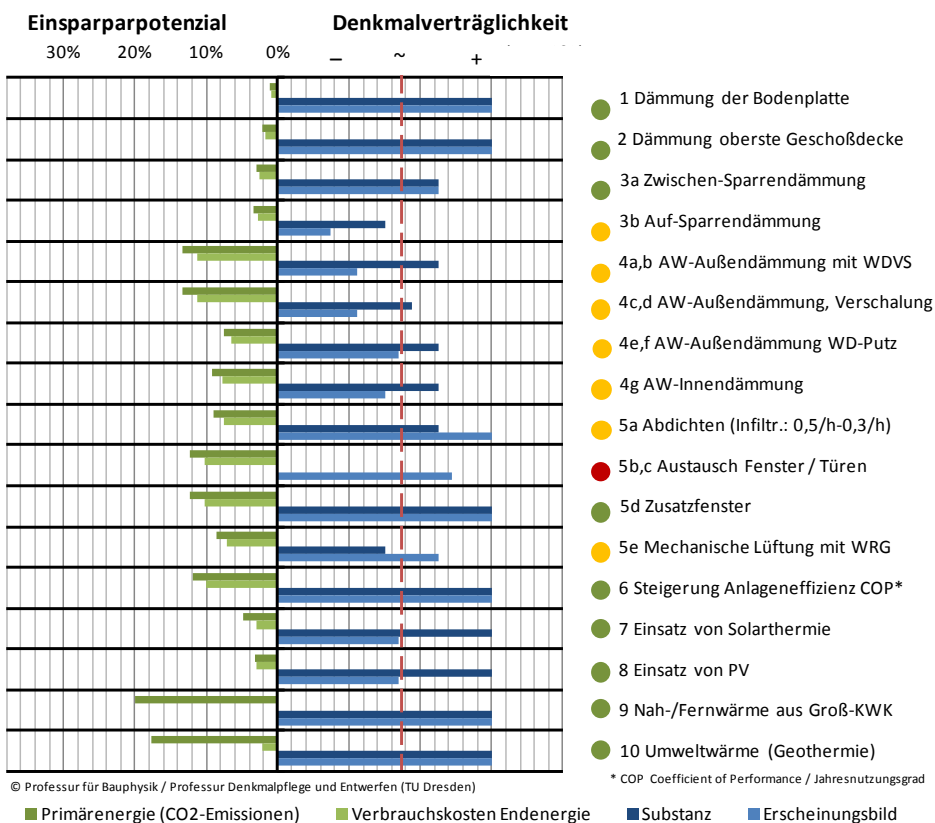

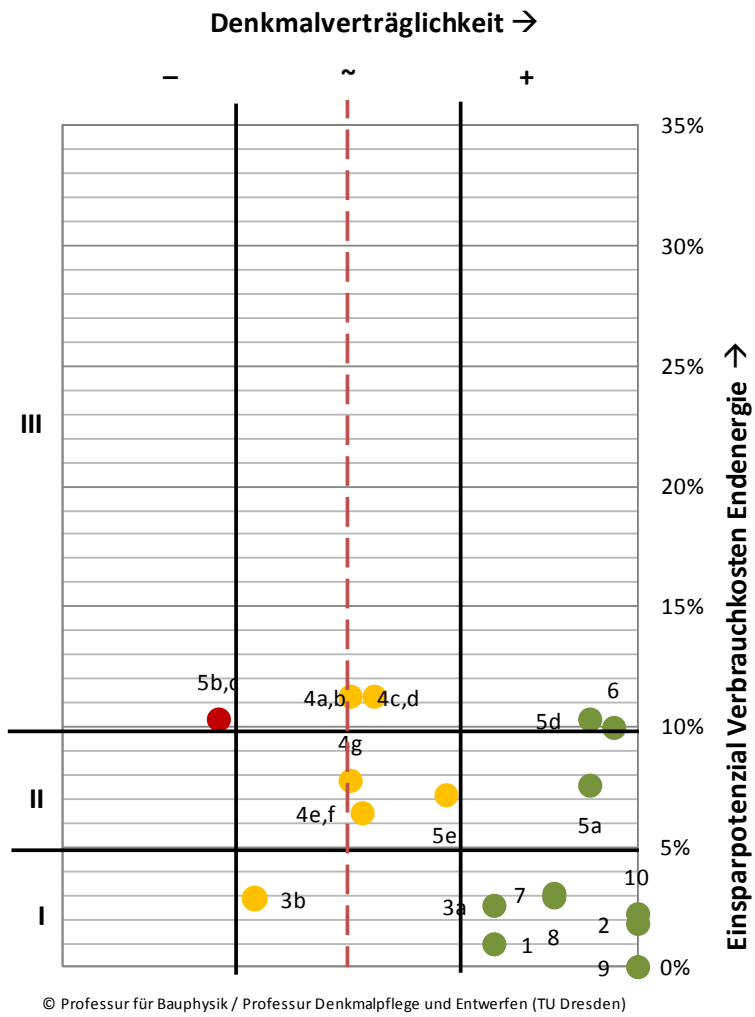

Potsdam

	Energieeinsparung	Denkmalverträglichkeit	Substanz	Erscheinungsbild	Reversibilität
1	0,7%	58,3%	-23%	-23%	-8%
2	1,1%	100,0%	-30%	-30%	-30%
3a	2,9%	75,0%	-23%	-23%	-23%
3b	3,3%	33,3%	-15%	-8%	-8%
4a,b	9,8%	31,3%	-11%	-9%	-8%
4c,d	9,8%	41,7%	-19%	-9%	-9%
4e,f	6,0%	54,2%	-23%	-15%	-11%
4g	7,2%	41,7%	-23%	-8%	-8%
5a	3,5%	91,7%	-23%	-30%	-30%
5b,c	5,0%	27,1%	0%	-24%	0%
5d	5,0%	91,7%	-30%	-30%	-23%
5e	3,8%	66,7%	-15%	-23%	-23%
6	6,7%	95,8%	-30%	-30%	-26%
7	1,9%	77,1%	-30%	-9%	-30%
8	1,5%	77,1%	-30%	-9%	-30%
9	5,5%	100,0%	-30%	-30%	-30%
10	5,6%	100,0%	-30%	-30%	-30%

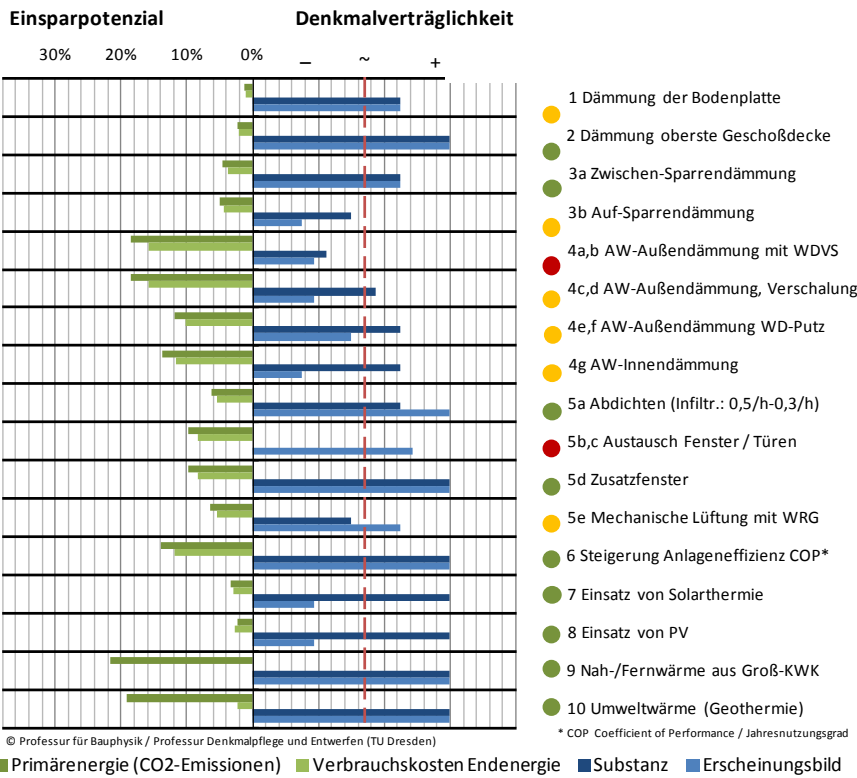

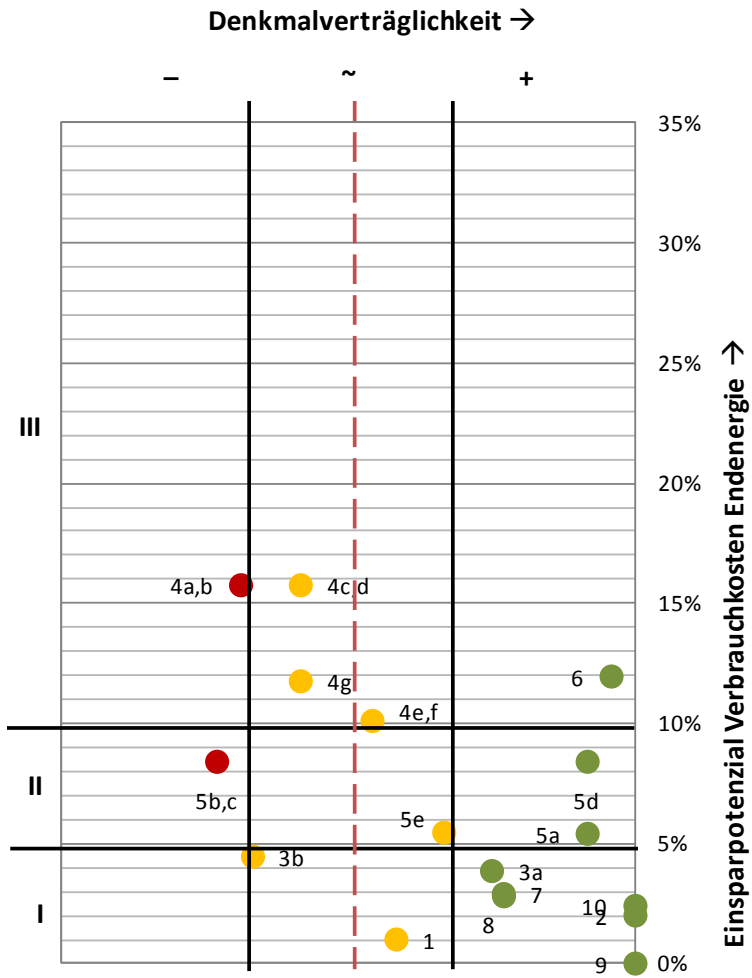

© Professur für Bauphysik / Professur Denkmalpflege und Entwerfen (TU Dresden)

2.7 CS7 Industrial Engineering School-Béjar/Salamanca (Spain)

2.7.1 LCS-Team

(P07)

Full name	Institution	Responsability	Mail
Pastora Vega	University of Salamanca	Vice-rector	pvega@usal.es
Esteban Sánchez Hernández	University of Salamanca	Principal of Bejar's Engineering School	esh@usal.es
Raúl Ovejero	University of Salamanca	Technical and economical responsible for the facilities of the Bejar's School	raulovej@usal.es
José L. Hernández García	CARTIF	CS7 responsible	josher@cartif.es
Miguel A. García Fuentes	CARTIF	Architect for diagnostic and evaluation	miggarr@cartif.es
Álvaro Corredera Cano	CARTIF	Technical responsible of the monitoring&control installation	alvcor@cartif.es
Javier Izard	Soliker/G1S	Industrial partner for the integration of solar energy	jizard@soliker.com
Óscar Montero	Soliker/G1S	Industrial partner for the integration of solar energy	omontero@soliker.com

2.7.2 Integration of heritage office in CS7

Within the Case study CS7 the Industrial Engineering School-Béjar/Salamanca all building and conservation action is directly related to the organisation of the University. First of all, anyone must contact with the "Infrastructure and economic assistant principal" of the School. Once the permission from this person is achieved, the next step is the contact with the "principal" of the School. In case the principal allows the intervention, the owner must be informed for the approval, in this case the University of Salamanca. For that purpose, the "Infrastructure and innovation vice-rector" is the responsible for that. Usually, this person keeps in contact with his/her people (the technical office of the University) and makes the decision. However, other times the vice-rector redirects directly to the technical office. That means there are internal laws which govern the actuations and installations in the University, but the final decision is always made by the University people.

There is no superior monument office involved in the decision making on the heritage building.

2.8 CS8 Strickbau Appenzell (Switzerland)

2.8.1 LCS-Team

Conservator	Fachstelle für Denkmalpflege der Stadt St. Gallen Neugasse 3 CH – 9004 St. Gallen Leader: Niklaus Ledergerber niklaus.ledergerber@stadt.sg.ch	Fon +41 71 224 55 81
Owner	Ueli Faessler Leugangenstraße 3 CH – 9057 Weissbad	
Case study leader 3ENCULT Scientific direction	Universität Stuttgart Institut für Werkstoffe im Bauwesen Pfaffenwaldring 4 D – 70569 Stuttgart Prof. Dr.-Ing. Harald Garrecht Harald.garrecht@iwb.uni-stuttgart.de Simone Reeb Simone.reeb@wib.uni-stuttgart.de	Fon +49 711 685 63323 Fon +49 711 685 62786
Historic preservation accompaniment	ETH Zürich Institut für Denkmalpflege und Bauforschung N Department Architektur HIT H 23.1 CH – 8093 Zürich Prof. Dr. Uta Hassler hassler@arch.ethz.ch Norbert Föhn foehn@arch.ethz.ch	Fon +41 44 632 22 84 Fon +41 44 633 63 12

2.8.2 Integration of heritage office in CS8

The energy retrofit of buildings is of high relevance, but the protection of the building and the living comfort has to be considered with the same weight. The goal of the case study is to develop appropriate technologies and methods to increase the energy efficiency for this special wood block construction. In order to develop an optimal and also historically acceptable retrofitting concept, the interdisciplinary cooperation between planners and conservators is mandatory. It is particularly important in connection with the planning of energy retrofitting that the conservators and authorities will be included in the project. So that the basically conditions are fixed (What actions are possible or impossible?) and can be integrated in the further planning process.

For this reason, in the context of this case study an on-site inspection took place within the possibility to get the first impressions of the building and its surrounding area and to develop the first sketches of drafts and to create the so-called Raumbuch. In preparation for the first round of discussion with the topic finding possible solutions for the retrofitting we had a closer look at the specifications of preservation to work out possible energy concepts which make sense and which are also supported from the curator of monuments. To this, the following documents were very helpful because they explain the importance of Strickbauten both in the social/historical and urban context:

- Energy and historical monuments - recommendations for energy improvement of historical buildings (Bundesamt für Energie; Eidgenössische Kommission für Denkmalpflege)
- Studies on rural building stock in Appenzell Ausserrhoden

In the first round of discussions the curators of monuments and the project partner of ETH Zurich worked together on commitments regarding the possible and not possible interventions in the building fabric or even the appearance of the object. The focus was here the protection of facade and of the historic woodwork in the living room. Since the opinion of the curators would in particular changes in the appearance of the house to the outside significantly affect the overall appearance of the building and therefore the environment. The developed possibilities of retrofitting which were the results of the meeting are shown in Figure 1 STEP 2. Based on the existing foundations was on our side the development of three retrofit measures in which the insulation of external walls in the focus. The presentation of these concepts with the respective strengths and weaknesses was carried out at a further discussion. The aim of the discussion was to bring out a first decision. The preference of the curators fell of the concept 3 because this has the best compatibility with a historic building and in addition is still economic installation so the curators opinion. The favorite version of insulation by which vacuum panels should be installed was out of the question. This type of insulation would be disproportionately expensive, due to the individual geometry of Strickbauten. Based on the decision we made on our part first calculations regarding the potential savings of heating energy demand which were presented in a further round of discussions. From the building physics point of view the evaluated wood fiber insulation with vapor barrier is critical. However the decision of the curators was to implement these in the case study and to work out possible improvements with a view of airtightness of the building. Due to the potential problematic situation relating to condensation in the construction because of this type of insulation it was considered that a corresponding monitoring and the design of the energy take place. The aim of the monitoring is therefore not only the monitoring of thermal-hygrictrims in the structural elements, but also to be able to give based on these recommendations for future insulation measures .

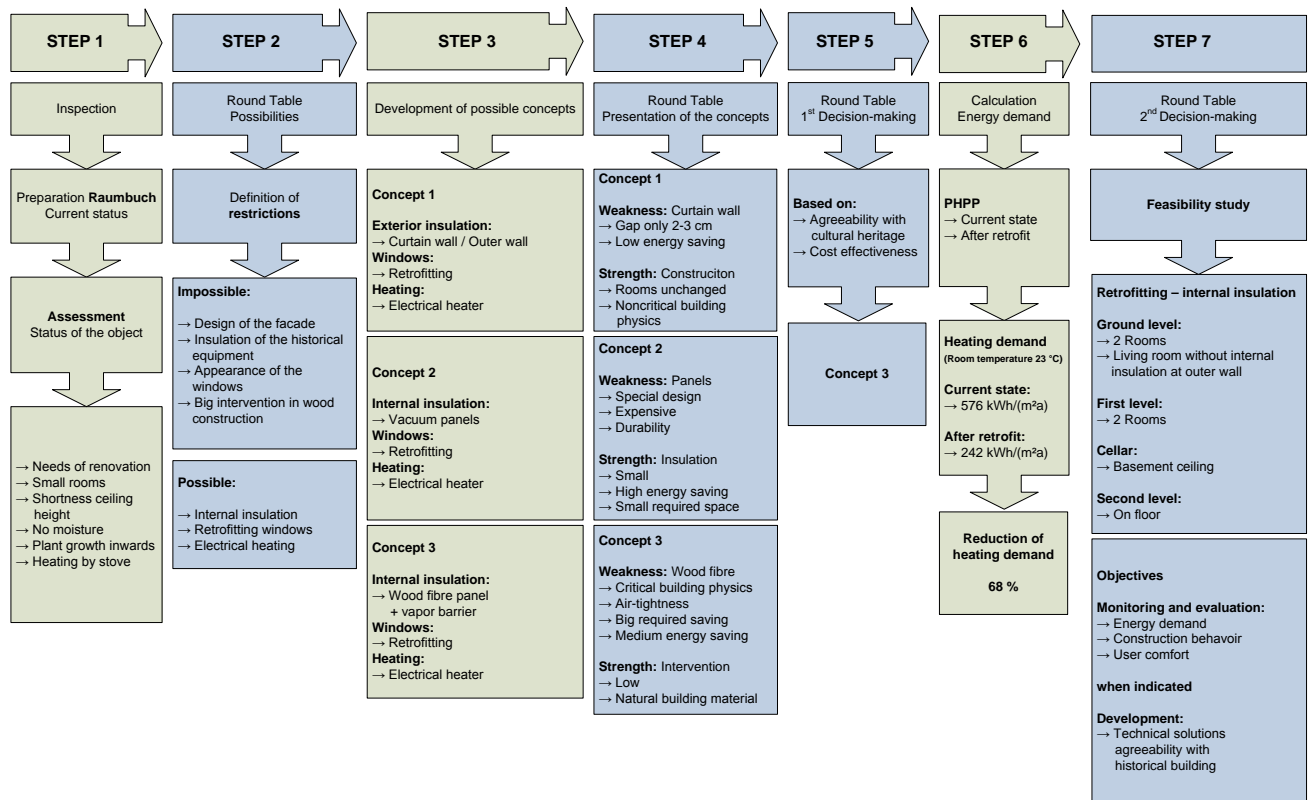

Figure 2.14: Decision process to find an optimized solution for an energetic retrofitting concept
 Blue marked = common discussions with all partners (planer, conservators etc.)
 Brown marked = Preparation and presentation of information (planer) for the conservators

3 Remarks

The Case studies of the 3ENCULT project are situated all over Europe. The consequences are not solely for the building types representing regional traditions for the sites but also for the conservation point of view. Although the heritage legislation in Europe acts in accordance with overall accepted Charters and Guidelines the organisation and evaluation is different in several countries (see also D2.1 Report on demand analysis and historic building classification, D2.2 = D3.2 Position Paper on criteria regarding the assessment of energy efficiency measures regarding their compatibility with conservation issues and D 2.5 Report on Methodology and Checklist). Thus also the post reporting of the conservation compatibility always has to refer to the specific efficiency measures on the specific object. Nevertheless the recommendations as proposed by the Austrian guideline (BDA Austria 2011) "Energieeffizienz am Baudenkmal" are generally accepted. Below there is given the translated text of 10 basic rules (p.8) about energy measures on heritage buildings from conservation point of view. At any point the need for a proof of damage freeness of the single energy efficiency measure is stressed. Moreover the importance to simulations is underlined.

The approach to heritage buildings for energy improvements is multidisciplinary. A weighing up process and discussion between experts is indispensable to reach the best solution.

- 1. THE ORIGINAL** Superior Objective of monument conservation is the unchanged preservation of the historic stock and its appearance as far as possible. In the case of necessary changes the preexisting state, the measures and the state after the measures are to be documented under preservation standards.
- 2. ANALYSIS** Most of the monuments exhibit a quite heterogeneous constitution grown in time. In the course of the planning a complete knowledge on the stock as well with respect to structurally as with respect to building physics is essential.
- 3. OVERALL PROJECT** Measures shall be based on a holistic planning and not focus on single actions. The achievement of single U-values or theoretical demands on thermal heat is not adequate. The aim is to reach the sensible improvement of the total energy budget of the building.
- 4. USER BEHAVIOR** The aim of the energetic retrofit shall not be based of specified guidelines like the standardized Energy Performance Certificate, but has to refer to the practical use and the behavior of the user in the specified object.
- 5. INDIVIDUAL** Monuments need individual solutions instead of standard formulations. This asks all parties involved the readiness of probably increased planning efforts, an improved quality assurance and intensified communication with and between expert, owner, investor and monument preservation until the termination of the measures.
- 6. REPAIRS** The first step is to look for sources of errors on the monument, do repairs and reactivate original functions to promote the historic ideas. No until the chances of restoration exploited one may decide on amendments or exchanges.
- 7. MATERIAL ACCORDANT** Necessary amendments in the course of energetic improvements have to be accordant to the existing materials.
- 8. FAULT TOLERANT** Given the fact that as well in production as in use there is never ideal conditions fault tolerant, repairable and reversible constructions are preferred.
- 9. RISK FREE** A long standing damage freeness is to guaranteed. For this often the participation of experts in building physics with major experience in monument conservation is necessary. Innovations and experiments on monuments are solely justifiable if this is included in serious scientific projects. In other respects it is imperative: better less and save - than much and risky.
- 10. FAR-SIGHTEDNESS/VISION** Measures on a monument queue in a stepwise development of the former centuries. Preservation forces all participants a vision beyond liability or time of depreciation.

Translated from source. <http://www.bda.at/documents/944221227.pdf>